

Condition Sensing Switches

Page 13-2

• Bulletin 803 Rotating Cam Limit Switches.....	Page 13-3
• Bulletin 836 Pressure Controls.....	Page 13-4
• Bulletin 836T Pressure Controls.....	Page 13-24
• Bulletin 837 Temperature Controls.....	Page 13-49
• Bulletin 808 Speed Switches.....	Web‡
• Bulletin 840 Automatic Float Switches.....	Web‡

‡Note: Information for this product line is available on the Industrial Controls Catalog web site: www.ab.com/catalogs.

NEMA Pressure Controls

	
Bulletin	836
Description	Style A – Pressure Controls (Internal Bellows) Style C – Pressure Controls (External Bellows)
Typical Applications	<ul style="list-style-type: none"> • Air Compressors • Compressed Air Monitor Systems • Liquid Level Control • Vacuum Transfer Systems • High Pressure Alert • Low Pressure Alert • Monitor Low and High Pressure
Operating Range	30 in. Hg vacuum to 900 psi
Max. Shaft Operating Speed	–
Enclosure Options	Open, Type 1, 4X, 4 & 13, 7 & 9 and 4 & 13
Differential	Independently adjustable
Repeat Accuracy	+/- 0.5%
Maximum Operating Limit	up to 1300 psi
Electrical Contacts	–
Electrical Ratings	–
Ambient Operating Temperature	-22...+150 °F (-30...+66 °C)
Ambient Storage Temperature	-22...+200 °F (-30...+93 °C)
Contact Ratings (Std.)	<ul style="list-style-type: none"> • Non-Inductive – 5 A, 240V / 3 A, 600V • Control Circuit – AC-125 VA, 24...600V DC-57.5 VA, 115...230V
Accessories/Modifications	Pulsation Snubbers, Specialty Contacts, Pilot Light Indicators, Quick Connects
Certifications	<ul style="list-style-type: none"> • UL & CSA (Standard Application and Haz Loc) • CE (Standard Application)
Product Selection	Page 13-4

NEMA Ratings and Test Values for AC Control Circuit Contacts at 50 or 60 Hz

NEMA Contact Rating Designation	Thermal Continuous Test Current [A]	Maximum Current [A]								VA	
		120V		240V		480V		600V		Make	Break
		Make	Break	Make	Break	Make	Break	Make	Break		
A600	10	60	6.00	30	3.00	15	1.50	12	1.20	7200	720
B600	5	30	3.00	15	1.50	7.50	0.75	6	0.60	3600	360
B150	5	30	3.00	—	—	—	—	—	—	3600	360

NEMA Pressure and Temperature Controls

Bulletin	836T	837
Features	<ul style="list-style-type: none"> Independently adjustable trip and reset settings Heavy-duty bellows or piston-style actuator High reliability, snap-action silver contacts On-machine style enclosure with removable access cover 	<ul style="list-style-type: none"> Independently adjustable trip and reset settings Heavy-duty bellows-type actuator High reliability, snap-action silver contacts Direct immersion or remote bulb and capillary sensing elements
Operating Range	30 in. Hg vacuum to 5000 psi	-60...+570 °F (-51.1...298.9 °C)
Differential	Independently adjustable	Independently adjustable
Repeat Accuracy	<ul style="list-style-type: none"> Bellows (+/-1%) Piston without seal (+/-3%) Piston with seal (+/-5%) 	+/- 2 °F (+/- 16.7 °C)
Maximum Operating Limit	up to 15 000 psi	up to 600 °F (315.6 °C)
Actuator Type	<ul style="list-style-type: none"> Style T – Bellows and Piston types available 	<ul style="list-style-type: none"> Style A/H/V – Bellows
Enclosure Options	Type 1/4/13, 7 & 9 and 4 & 13	Open, Type 1, 4 & 13, 7 & 9 and 4 & 13
Ambient Operating Temperature	-22...+150 °F (-30...+66 °C)	-22...+150 °F (-30...+66 °C)
Ambient Storage Temperature	-22...+200 °F (-30...+93 °C)	-22...+200 °F (-30...+93 °C)
Contact Ratings (Std.)	<ul style="list-style-type: none"> 2 Circuit – NEMA A600 4 Circuit – NEMA B150 	<ul style="list-style-type: none"> Non-Inductive – 5 A, 240V / 3 A, 600V Control Circuit – AC-125 VA, 24...600V DC-57.5 VA, 115...230V
Accessories/Modifications	Pulsation Snubbers, Pilot Light Indicators, Quick Connects	Custom Capillary Lengths & Materials, Pilot Light Indicators, Quick Connects
Certifications	<ul style="list-style-type: none"> UL & CSA (Standard Application and Haz Loc) CE (Standard Application) 	<ul style="list-style-type: none"> UL & CSA (Standard Application and Haz Loc) CE (Standard Application)
Product Selection	Page 13-24	Page 13-49

Bulletin 803 Rotating Cam Limit Switches — Renewal Parts



Bulletin 803 Style F

Contact Blocks

The following are the contact blocks offered for the Bulletin 803 Style A, B, and F.

Contact Blocks for Style A, B, and F	
Description	Cat. No.
Style A Contact Block	WX110280
Style B Contact Block	WX265557
Style F Contact Block	WX286260

Cam Kits

The following are the cam kits offered for the Bulletin 803 Style P.

Cam Code Designator	Adjustable Degrees of Dwell		Cam Kit*
	N.C. Contact Opens	N.O. Contact Remains Closed	Cat. No.
3	27...33°	327...333°	803-NK33
4	33...39°	321...327°	803-NK34
5	38...49°	311...322°	803-NK35
6	48...69°	291...312°	803-NK36
7	68...109°	251...292°	803-NK37
8	108...189°	171...252°	803-NK38
9	148...269°	91...212°	803-NK39
0	188...349°	11...172°	803-NK40

* Kit includes two cam and mounting hardware for one circuit.



Bulletin 836 Pressure Controls

- Operating ranges from 30 in. Hg vacuum...900 psi
- Independently adjustable range and differential
- Copper alloy and stainless steel bellows
- 7/16-20 S.A.E. and 1/4 in. N.P.T. connections
- Variety of contact blocks available
- Open Type, Type 1, Type 4&13, Type 4X and Type 7&9 and 4&13 combination enclosures

Table of Contents

Product Overview this page
 Technical Data 13-6
 Product Selection 13-10
 Modifications 13-14
 Accessories 13-16
 Factory Options 13-18
 Refrigeration Controls 13-19
 Approximate Dimensions 13-22

Standards Compliance and Certifications

(For file and guide numbers, see page 13-18)



Product Overview

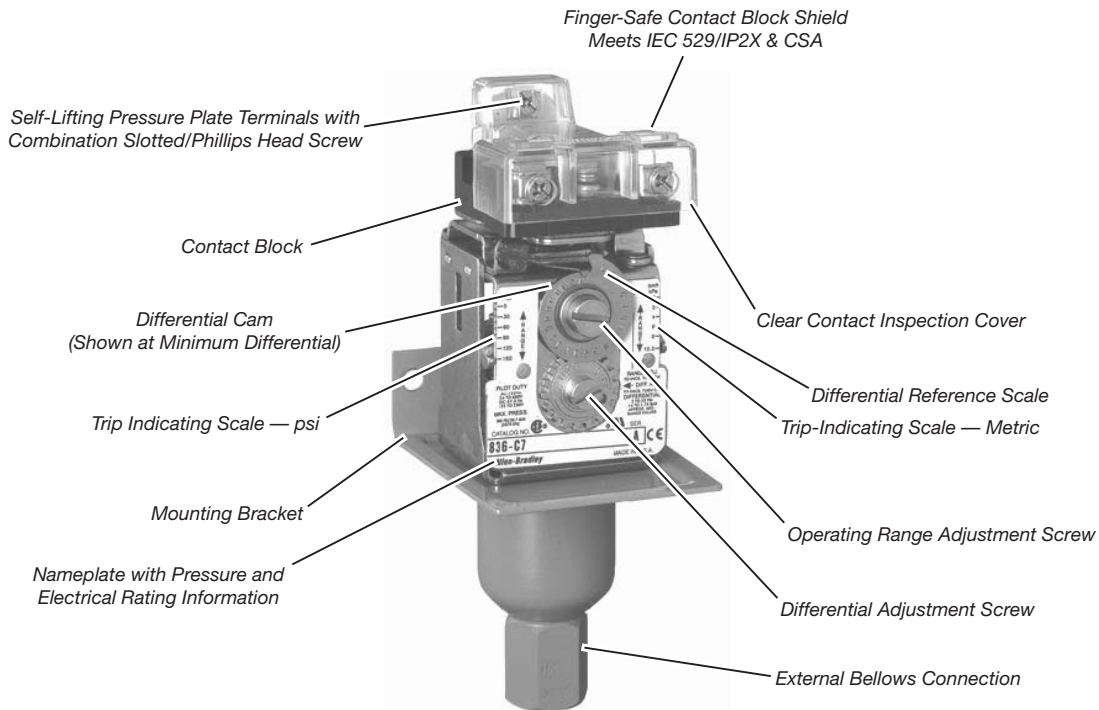

Description

Bulletin 836 Pressure Controls are designed for general industrial use to control and detect pressure. Allen-Bradley Bulletin 836 Pressure Controls can be used in pneumatic and hydraulic systems. Pressure controls use copper alloy or stainless steel bellows. The design and high-quality components provide long life operation with air, water, oil, non-corrosive liquids, vapors, gases, and some corrosive liquids and gases.

Pressure controls feature snap-action precision switches equipped with silver contacts. The straight in-line and relatively friction-free construction provides accurate and consistent operation regardless of the angle at which the controls are mounted. Pressure controls are designed for easy adjustment of both trip and reset pressures.

Allen-Bradley Bulletin 836 Pressure Controls are used in many types of industries and applications. They can be used to control pneumatic systems, maintaining preset pressures between two values. Pressure controls can be used to detect overpressures of gases or liquids to protect machines, processes, and personnel. They can also be used to detect low pressures to protect equipment from loss of coolants and lubrication.

Bulletin 836 Pressure Controls are offered in a variety of styles to meet a wide range of applications. The devices are available in Type 1, 4 & 13, 4X, 7 & 9, and 4 & 13 combined and open type without enclosure for panel mounting. Pressure controls have a wide variety of contact modifications to meet most control circuit requirements. The controls have adjustable pressure ranges from 30 in. Hg vacuum...900 psi with corresponding differentials. Accessories and modifications are available to tailor the device to meet most application requirements.

Applications

- Air compressors
- Compressed air monitor systems
- Liquid level control
- Vacuum transfer systems
- High pressure alert
- Low pressure alert
- Monitor low and high Pressure

Style A — Small Size, Internal Copper Alloy Bellows



Style A

- Independently adjustable range and differential
- 7/16-20 SAE flare for 1/4 in. copper tubing connection
- Adjustable operating range — 30 in. Hg vacuum...375 psi
- Maximum line pressure — up to 750 psi
- Occasional surge pressure — up to 850 psi

Style C — Wider Ranges, External Bellows



Style C

- Independently adjustable range and differential
- 1/4 in N.P.T. female pipe connection
- 3/8 in N.P.T. female pipe connection (836-C1 and 836-C1A only)

Copper Alloy Bellows

- Adjustable operating range — 30 in. Hg vacuum...900 psi
- Maximum line pressure — up to 1300 psi
- Occasional surge pressure — up to 1600 psi

Type 316 Stainless Steel Bellows

- Adjustable operating range — 30 in. Hg vacuum...375 psi
- Maximum line pressure — up to 650 psi
- Occasional surge pressure — up to 650 psi

Refrigeration Controls - See page 13-19



Style H

- High-pressure refrigeration controls

Style L

- Low-pressure refrigeration controls

Style P

- High-pressure definite purpose controls

Technical Terms

Adjustable operating range — Total span within which the contacts can be adjusted to trip and reset.

Trip setting — Higher pressure setting at which value the contacts transfer from their normal state to a changed state.

Reset setting — Lower pressure setting at which value the contacts return to their normal state.

Adjustable differential — Difference between the trip and reset values.

Minimum differential — When the differential is set to the lowest pressure difference between trip and reset.

Maximum differential — When the differential is set to the widest pressure difference between trip and reset.

Maximum occasional surge pressure — Maximum surge pressure that can be applied to the actuator. Surges or transients can occur during startup and shutdown of a machine or system. Expressed in milliseconds, complex electronic instrumentation is required to measure the varying amplitude, frequency, and duration of this wave form. Extreme surges that occur approximately eight times in a 24-hour period are negligible.

Maximum line pressure — Maximum sustained pressure that can be applied to the bellows without permanent damage. The control should not be cycled at this pressure.

Positive pressure — Any pressure more than 0 psi. See Figure 2.

- **Trip setting** — Increasing pressure setting when contacts change state.
- **Reset setting** — Decreasing pressure setting when contacts return to their normal state.

Vacuum (negative pressure) — Any pressure less than 0 psi, inches of Hg vacuum. See Figure 2.

- **Trip setting** — Decreasing vacuum setting when contacts change state.
- **Reset setting** — Increasing vacuum setting when contacts return to their normal state.

psi — Pounds per square inch. Devices listed are in gauge pressure units which use atmospheric pressure as a reference. Atmospheric pressure at sea level is approximately 14.7 psi or 30 in. Hg.

Operating range adjustment screw — This screw is used to adjust the trip setting by varying the force of the main spring.

Differential adjustment screw — This screw is used to adjust reset setting by varying the force of the differential blade spring.

Pressure media — There are many types of pressure media that are controlled. Examples include air, water, hydraulic fluids and other types of gases and liquids. The type of media and maximum system pressure will determine the type of actuator used for the pressure control application. See page 13-9.

Pressure connection — Common types of pressure connections used in control systems are 1/4 in. and 3/8 in. female pipe threads, and 7/16 in. — 20 SAE copper tubing.

Contact configuration — There are many types of contact configurations available. Bulletin 836 Style A and C pressure controls offer a wide variety of contact configurations for both automatic operation and manual reset. See page 13-14.

Figure 1
 Graphics to illustrate technical terms

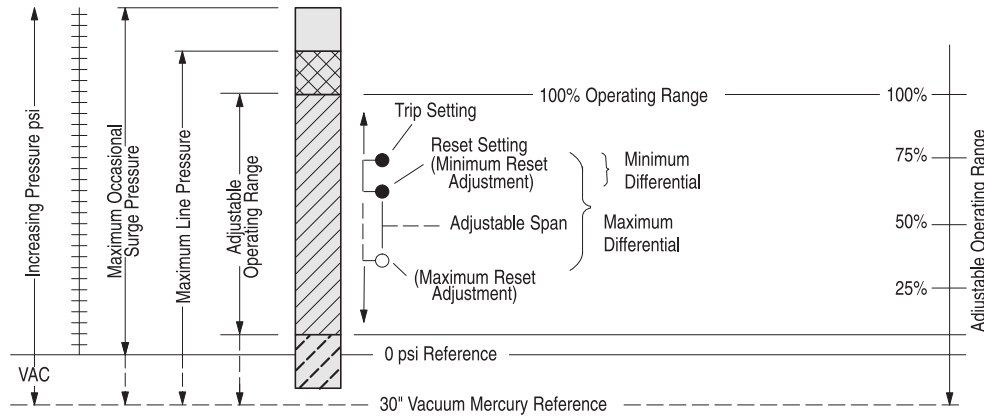
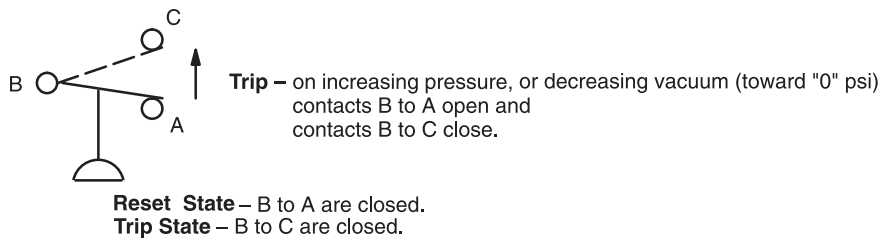

Figure 2
 Positive pressure or vacuum



Theory of Operation

Bulletin 836 Pressure Controls are designed to open or close electrical circuits in response to changes in pneumatic (air or gas) or hydraulic (water or oil) pressure. Figure 3 is a simplified drawing of a pressure control.

The system pressure is connected to the control at the pressure connection. The system pressure is applied directly to the bellows. As pressure rises, the bellows exerts force on the main spring. When the threshold force of the main spring is overcome, it transfers the motion to the contact block, causing the contacts to actuate — this is referred to as the trip setting. As pressure decreases, the main spring will retract, causing the secondary differential blade spring to activate and return the contacts to their normal state — this is referred to as reset setting.

Varying the force of the main spring (by turning the operating range adjustment screw) determines where the contacts will trip. Varying the force of the secondary differential blade spring (by turning the differential adjustment screw) determines where the contacts will reset.

Figure 3
 Basic mechanical structure

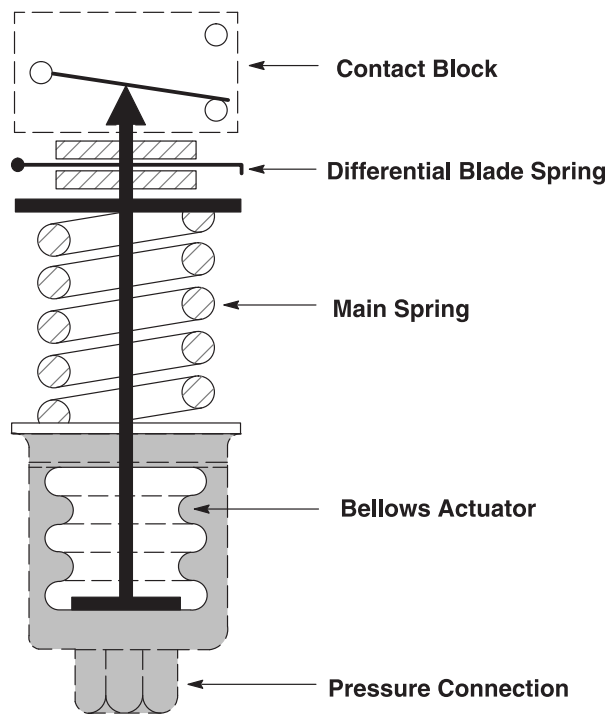

Applications for Control

Pressure controls can be used to either control or monitor a machine or process. Figure 4 shows a typical control application. Here, pressure is controlled within predetermined high and low values. Figure 5 shows a typical monitoring application. Here, pressure is monitored between a high and low value, signaling when a preset limit has been exceeded.

Figure 4
 Typical control application

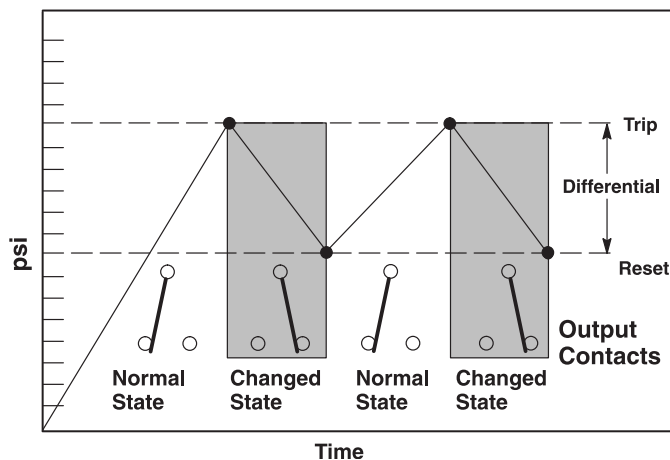
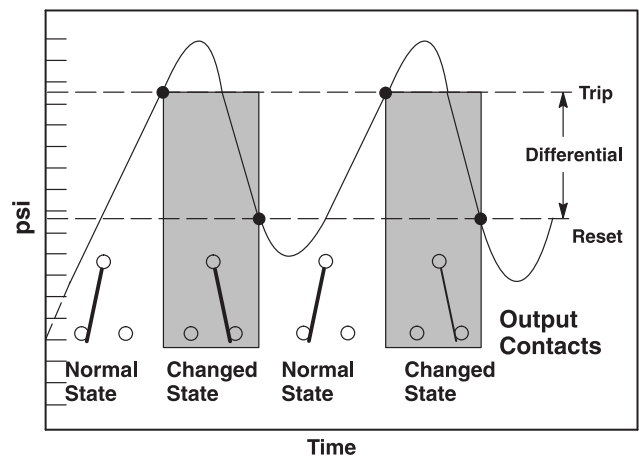

Figure 5
 Typical monitoring application



Control Settings

Allen-Bradley controls are designed for ease of setting to help minimize installation time. Standard controls shipped from the factory are set at the maximum operating range and minimum differential. By following this simple two-step process, the control can be set to the specific requirements for each application. See Figure 6.

Step 1 — Adjust trip setting

The trip setting is achieved by turning the operating range adjustment screw. Turn the range screw counterclockwise to lower the trip setting, or clockwise to raise the trip setting. The approximate trip setting is shown on the indicating scale.

Note: Turning the operating range adjustment screw will change both the trip and reset settings in virtually equal increments.

Step 2 — Adjust reset setting

The reset setting is achieved by turning the differential adjustment screw counterclockwise to increase the differential, or clockwise to decrease the differential.

Note: Adjusting the differential has little or no affect upon the trip setting.

Figure 6
 Trip and reset adjustment

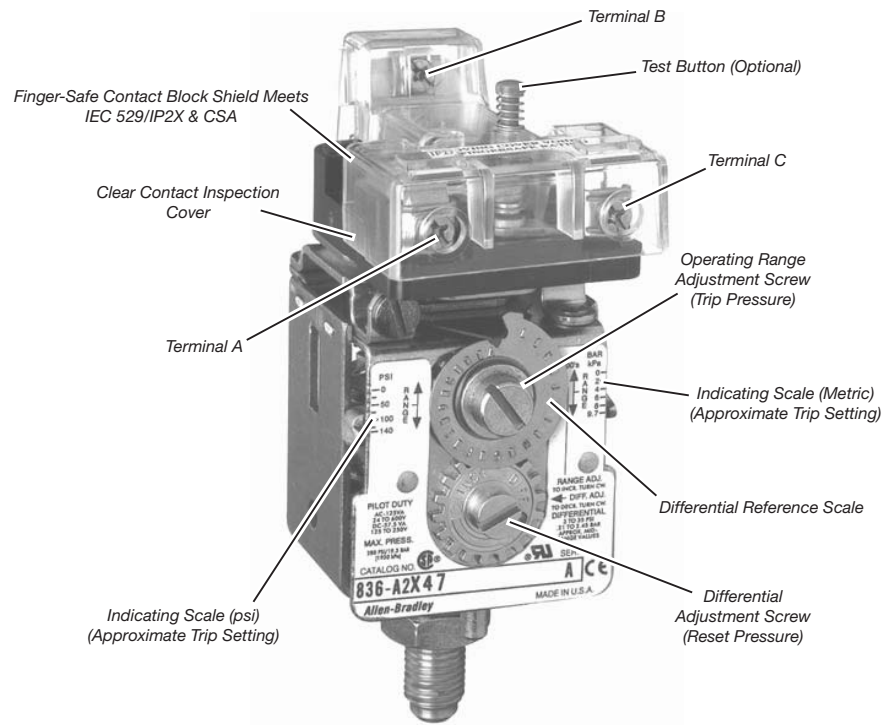

Repeat Accuracy and Mechanical Life

The design and construction of Bulletin 836 Styles A and C controls provide a typical repeat accuracy of + 0.5% or better. Repeat accuracy is based on percent of maximum range, evaluated from test data and calculated using the formula per ICS 2-225 standards.

Repeat accuracy and mechanical life of bellows type controls is graphically illustrated in Figure 7. For general applications, controls selected where the contacts operate between 30...80% of the operating range and where the maximum line and surge pressures do not exceed the specified values will provide excellent life and repeat accuracy. For more specific applications, it is important to note that the controls are designed to operate **below** or **above** these values. However, there may be a small trade-off between the factors of repeat accuracy and mechanical life.

Figure 7
 Repeat accuracy versus mechanical life graph

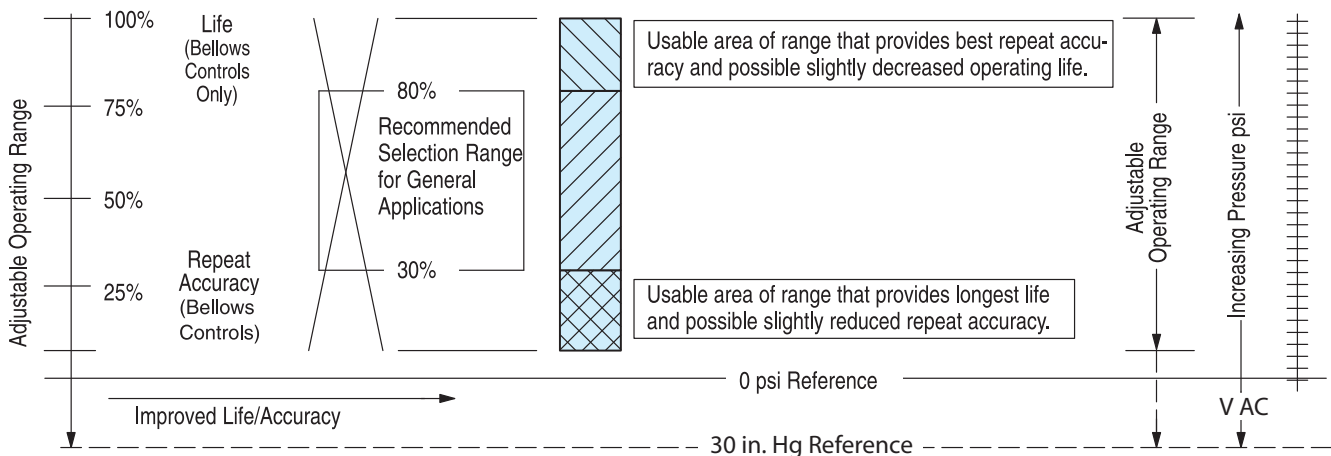

Standard Contacts

Snap-action contact operation

Contact blocks are single-pole, double-throw and can be wired to open or close on increasing or decreasing pressures.

Non-inductive ratings

5 A, 240V
 3 A, 600V

Control circuit ratings

AC - 125 VA, 24...600V
 DC - 57.5 VA, 115...230V

Standard Contact Wiring Configurations

Single-pole double throw

Positive Pressure

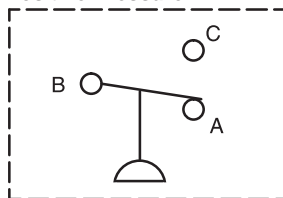

Vacuum (Negative Pressure)

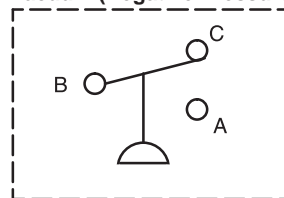

Note: NEMA does not rate contacts to switch low voltage and current.

Bulletin 836 Styles A and C Pressure Controls are supplied with silver contacts. The devices are designed to deliver high-force snap action to the contacts. This provides exceptional contact fidelity at 24V DC I/O card current level entry when the control is protected in a suitable enclosure for the surrounding environment.

Special Controls

A large number of unlisted catalog modifications and complete devices are available for specific and OEM applications.

Special controls and modification service is available to meet many applications unique to the OEM market.

Please contact your local Rockwell Automation sales office or Allen-Bradley distributor for assistance with specific modified controls and accessories.

Temperature Range

Temperature range at +32 °F (0 °C) or below is based on the absence of freezing moisture, water, or other fluids that may solidify and impede operation of the control. Temperature ratings are as follows:

Operating:	-22... +150 °F (-30...+66 °C)
Storage:	-22...+200 °F (-30...+93 °C)

Factory-Set Pressure Controls

Rockwell Automation will factory set pressure controls to customer-specified values. Unspecified pressure controls shipped from the factory are set at the maximum operating range and minimum differential. See Factory Options, page 13-18.

Pressure Control Selection

The selection table below is an overview of the three types of Allen-Bradley Bulletin 836 Pressure Controls. Each type of control is suitable for use on many types of applications. Pressure ranges, pressure connections, enclosure types, and the compatibility of the actuator with different types of pressure media are given to assist in the selection of which type of control to use.

	836 Style A	836 Style C	836 Style C
Actuator Type	Internal Bellows, Copper Alloy	External Bellows, Copper Alloy	External Bellows, Stainless Steel Type 316
Adjustable Operating Ranges	30 in. Hg Vacuum...375 psi	30 in. Hg Vacuum...900 psi	30 in. Hg Vacuum...375 psi
Adjustable Differentials	2...95 psi	0.2...125 psi	0.4...80 psi
Maximum Line Pressures	up to 750 psi	up to 1300 psi	up to 650 psi
Occasional Surge Pressures	up to 850 psi	up to 1600 psi	up to 650 psi
Pressure Media			
Air	•	•	•
Water	•	•	•
Hydraulic Fluids	•	•	•
Liquids:			
Corrosive*			•
Non-Corrosive	•	•	•
Gases:			
Corrosive*			•
Non-Corrosive	•	•	•
Enclosures			
Open Type	•	•	•
Type 1	•	•	•
Type 4 & 13	•	•	•
Type 4X		•	•
Type 7 & 9 and 4 & 13	•	•	•
Pipe Connections			
Pressure Connection	7/16 in.-20 SAE Flare for 1/4 in. Copper Tubing	1/4 in. N.P.T. Female Pipe Thread or 3/8 in. N.P.S. Female Pipe connection (836-C1 and 836-C1A only)	1/4 in. N.P.T. Female Pipe Thread

* Corrosive liquids and gases compatible with Type 316 Stainless Steel.

Pressure Controls

Product Selection

Ordering Bulletin 836 Pressure Controls

When ordering Bulletin 836 Pressure Controls, consider the following:

- Device style
- Adjustable operating range
- Adjustable differential
- Maximum line pressure
- Occasional surge pressure
- Pressure media
- Enclosure type
- Pressure connection

How to Order

- Step 1: Basic Device**
Select a catalog number for the basic device.
See pages 13-11...13-13
- Step 2: Modifications**
If required, add the appropriate modification suffix code(s) to the catalog number of the basic device.
See page 13-14
- Step 3: Accessories**
If required, select appropriate accessories.
See page 13-16
- Step 4: Factory Options**
Factory-set pressure controls.
See page 13-18

Catalog Number Explanation

Note: Catalog numbers must not include blank spaces.

836 – A 1 A X9

a *b* *c* *d*

a

Style of Device	
Code	Description
A	Internal Bellows
C	External Bellows

b

Pressure Specifications
See "Pressure Specifications" on pages 13-11...13-13

c

Enclosure Type	
Code	Description
A	Type 1
E	Type 7 & 9 and 4 & 13 Combined Metallic (Aluminum)
J	Type 4 & 13 Metallic (Aluminum)
S	Type 4X Non-Metallic
None	Without Enclosure

d

Modification	
Code	Description
X_	Add suffix codes in descending order whenever possible (see page 13-14)

Conversion Factors

Conversion Factors (Rounded)

- psi x 703.1 = mm/H₂O
- psi x 27.68 = in. H₂O
- psi x 51.71 = mm/Hg
- psi x 2.036 = in. Hg
- psi x 0.0703 = kg/cm²
- psi x 0.0689 = bar
- psi x 68.95 = mbar
- psi x 6895 = Pa
- psi x 6.895 = kPa

Note: psi — pounds per square inch (gauge)
H₂O at 39.2 °F/Hg at 32 °F





*Style A Internal Bellows —
 Copper Alloy, Type 1*



*Style A Internal Bellows —
 Copper Alloy, Type 4 & 13*

**Style A Internal Bellows —
 Copper Alloy Bellows* With 7/16 in. — 20 SAE Flare for 1/4 in. Copper Tubing Connection**

Standard pressure controls shipped from the factory are set at the maximum operating range and minimum differential.

Pressure Specifications				Enclosure Type	
Adjustable Operating Range [in. Hg Vacuum...psi]*	Adjustable Differential [psi] (Approximate Mid-Range Values)	Maximum psi		Open Type (Without Enclosure)	Type 1
		Line Pressure	Occasional Surge Pressure‡	Cat. No.	Cat. No.
30 in. Vacuum...75	2...20§	160	160	836-A1	836-A1A
6...140	3...35	280	340	836-A2	836-A2A
12...250	6...65	500	600	836-A3	836-A3A
16...375	8...95	750	850	836-A4	836-A4A

**Style A Internal Bellows —
 Copper Alloy Bellows* With 7/16 in. — 20 SAE Flare for 1/4 in. Copper Tubing Connection**

Standard pressure controls shipped from the factory are set at the maximum operating range and minimum differential.

Pressure Specifications				Enclosure Type	
Adjustable Operating Range [in. Hg Vacuum...psi]*	Adjustable Differential [psi] (Approximate Mid-Range Values)	Maximum psi		Type 4 & 13	Type 7 & 9 and 4 & 13*
		Line Pressure	Occasional Surge Pressure‡	Cat. No.	Cat. No.
30 Vacuum...75	2...20§	160	160	836-A1J	836-A1E
6...140	3...35	280	340	836-A2J	836-A2E
12...250	6...65	500	600	836-A3J	836-A3E
16...375	8...95	750	850	836-A4J	836-A4E

* Copper alloy bellows may be used on water or air, and other liquids or gases not corrosive to this alloy.

* For applications where settings approach 0 psi, select a control that has an adjustable range that goes into vacuum.

‡ Transients (pulses) can occur in a system prior to reaching a steady-state condition. Surge pressures within published values generated during startup or shutdown of a machine or system, not exceeding eight times in a 24-hour period, are negligible.

§ To determine differential in inches of mercury vacuum multiply value in table by 2.036 (or approximately 2).

* The combined Type 7 & 9 and 4 & 13 Hazardous Gas and Dust service enclosure is supplied with special gasket and O-ring seal to diminish/exclude moisture, fluids, and dust from entering the enclosure. Enclosures rated 7 & 9 only are not designed to restrict moisture from entering the enclosure, which is common to outdoor service. Enclosure is rated for the following environments:

- CLASS I Groups C,D
- CLASS II Groups E,F,G
- CLASS III

Pressure Controls

Product Selection, Continued



Style C External Bellows —
Copper Alloy, Type 1 With Pilot Light Option



Style C External Bellows —
Copper Alloy, Type 4 & 13

Style C External Bellows — Copper Alloy Bellows* With 1/4 in. N.P.T. Female Pipe Connection

Standard pressure controls shipped from the factory are set at the maximum operating range and minimum differential.

Pressure Specifications				Enclosure Type		
Adjustable Operating Range [in. Hg Vacuum...psi]*	Adjustable Differential [psi] (Approximate Mid-Range Values)	Maximum psi		Open Type (Without Enclosure)	Type 1	Type 4 & 13
		Line Pressure	Occasional Surge Pressure‡	Cat. No.	Cat. No.	Cat. No.
12 in. Vacuum...8>	0.2...2.5§	25	30	836-C1	836-C1A	—
30 in. Vacuum...10	0.4...6§	65	75	836-C2	836-C2A	836-C2J
0.8...30	0.4...6	80	80	836-C3	836-C3A	836-C3J
30 in. Vacuum...45	1...12§	175	190	836-C4	836-C4A	836-C4J
2...80	1...12	190	210	836-C5	836-C5A	836-C5J
30 in. Vacuum...100	2...25§	300	375	836-C6	836-C6A	836-C6J
4...150	2...25	300	375	836-C7	836-C7A	836-C7J
6...250	4...45	500	650	836-C8	836-C8A	836-C8J
35...375	6...80	900	1200	836-C9	836-C9A	836-C9J
50...500	12...115	1300	1600	836-C10	836-C10A	836-C10J
50...650	16...115	1300	1600	836-C11	836-C11A	836-C11J
200...900	25...115	1300	1600	836-C12	836-C12A	836-C12J

Style C External Bellows — Copper Alloy Bellows* With 1/4 in. N.P.T. Female Pipe Connection

Standard pressure controls shipped from the factory are set at the maximum operating range and minimum differential.

Pressure Specifications				Enclosure Type	
Adjustable Operating Range [in. Hg Vacuum...psi]*	Adjustable Differential [psi] (Approximate Mid-Range Values)	Maximum psi		Type 4X	Type 7 & 9 and 4 & 13*
		Line Pressure	Occasional Surge Pressure‡	Cat. No.	Cat. No.
12 in. Vacuum...8>	0.2...2.5§	25	30	—	—
30 in. Vacuum...10	0.4...6§	65	75	836-C2S	836-C2E
0.8...30	0.4...6	80	80	836-C3S	836-C3E
30 in. Vacuum...45	1...12§	175	190	836-C4S	836-C4E
2...80	1...12	190	210	836-C5S	836-C5E
30 in. Vacuum...100	2...25§	300	375	836-C6S	836-C6E
4...150	2...25	300	375	836-C7S	836-C7E
6...250	4...45	500	650	836-C8S	836-C8E
35...375	6...80	900	1200	836-C9S	836-C9E
50...500	12...115	1300	1600	836-C10S	836-C10E
50...650	16...115	1300	1600	836-C11S	836-C11E
200...900	25...115	1300	1600	836-C12S	836-C12E

* Copper alloy bellows may be used on water or air, and other liquids or gases not corrosive to this alloy.

§ For applications where settings approach 0 psi, select a control that has an adjustable range that goes into vacuum.

‡ Transients (pulses) can occur in a system prior to reaching a steady-state condition. Surge pressures within published values generated during startup or shutdown of a machine or system, not exceeding eight times in a 24-hour period, are negligible.

§ To determine differential in. Hg vacuum, multiply value in table by 2.036 (or approximately 2).

* The combined Type 7 & 9 and 4 & 13 Hazardous Gas and Dust service enclosure is supplied with special gasket and O-ring seal to diminish/exclude moisture, fluids, and dust from entering the enclosure. Enclosures rated 7 & 9 only are not designed to restrict moisture from entering the enclosure, which is common to outdoor service. Enclosure is rated for the following environments:

- CLASS I Groups C,D
- CLASS II Groups E,F,G
- CLASS III

> With 3/8 in. N.P.S.F. female pipe connection.





**Style C External Bellows —
 Type 4X Glass Reinforced Polyester Enclosure**



**Style C External Bellows —
 Stainless Steel, Type 7 & 9 and 4 & 13 Combined**

**Style C External Bellows —
 Type 316 Stainless Steel Bellows* With 1/4 in. N.P.T. Female Pipe Connection**

Standard pressure controls shipped from the factory are set at the maximum operating range and minimum differential.

Pressure Specifications				Enclosure Type				
Adjustable Operating Range [in. Hg Vacuum...psi]*	Adjustable Differential [psi] (Approximate Mid-Range Values)	Maximum psi		Open Type (Without Enclosure)	Type 1	Type 4 & 13	Type 4X	Type 7 & 9 and 4 & 13‡
		Line Pressure	Occasional Surge Pressure‡	Cat. No.	Cat. No.	Cat. No.	Cat. No.	Cat. No.
30 in. Vacuum...10	0.4...6§	65	65	836-C60	836-C60A	836-C60J	836-C60S	836-C60E
0.8...30	0.4...6	65	65	836-C61	836-C61A	836-C61J	836-C61S	836-C61E
30 in. Vacuum...100	2...25§	270	270	836-C62	836-C62A	836-C62J	836-C62S	836-C62E
4...150	2...25	270	270	836-C63	836-C63A	836-C63J	836-C63S	836-C63E
6...250	4...45	450	450	836-C64	836-C64A	836-C64J	836-C64S	836-C64E
35...375	8...80	650	650	836-C65	836-C65A	836-C65J	836-C65S	836-C65E

* Type 316 stainless steel bellows are available for more corrosive liquids or gases.

‡ For applications where settings approach 0 psi, select a control that has an adjustable range that goes into vacuum.

‡ Transients (pulses) can occur in a system prior to reaching a steady-state condition. Surge pressures within published values generated during startup or shutdown of a machine or system, not exceeding eight times in a 24-hour period, are negligible.

§ To determine differential in. Hg vacuum, multiply value in table by 2.036 (or approximately 2).

‡ The combined Type 7 & 9 and 4 & 13 Hazardous Gas and Dust service enclosure is supplied with special gasket and O-ring seal to diminish/exclude moisture, fluids, and dust from entering the enclosure. Enclosures rated 7 & 9 only are not designed to restrict moisture from entering the enclosure, which is common to outdoor service. Enclosure is rated for the following environments:

- CLASS I Groups C,D
- CLASS II Groups E,F,G
- CLASS III

Bulletin 836
Pressure Controls
Modifications

Ordering Modifications

Modifications are ordered by adding the appropriate modification suffix code to the catalog number of the basic device. Add suffix codes to the catalog number in descending order (highest number first).

Modifications

Contact Blocks — Trip pressure-indicating scales are supplied on controls with standard contact block.

Description	Rating	Symbol	Suffix Code	
Automatic Operation				
Standard Contact Block — Single-pole, double-throw, snap-action. Supplied when a contact block suffix is not added to the catalog number.	Control Circuit Rating: See Specifications on page 13-9		—	
Single-pole double-throw — slow-acting contact with no snap action. Contacts close on rise and close on fall with an open circuit between contact closures.	Control Circuit Rating: AC-125VA, 24...250V		*⊛	X171
Single-pole single-throw, normally open — closes on rise.	0.5 Hp, 115V AC 1 HP, 230V AC Control Circuit Rating: AC-125 VA, 24...110V		*⊛	X221
Single-pole single-throw, normally closed — opens on rise.	AC-345 VA, 110...600V DC-57.5 VA, 110...250V		*⊛	X231
Single-pole single-throw, normally open — closes on rise.	1 Hp, 115V AC 1.5 Hp, 230V AC Control Circuit Rating: AC-600 VA, 110...600V		*⊛	X321
Single-pole single-throw, normally closed — opens on rise.	DC-57.5 VA, 110...250V		*⊛	X331
External Manual Reset (Not available in Type 4X Enclosures) †§				
Single-pole single-throw, normally open — contacts open at a predetermined setting on fall and remain open until system is restored to normal run conditions, at which time contacts can be manually reset.	Non-inductive: 5 A, 240V 3 A, 600V Control Circuit Rating: AC-125 VA, 24...600V DC-57.5 VA, 115...230V		*†§♣	X140
Single-pole single-throw, normally closed — contacts open on rise and remain open until system is restored to normal run conditions, at which time contacts can be manually reset.			*†§♣	X150
Single-pole double-throw, one contact normally closed — contact opens on rise and remains open until system is restored to normal run conditions, at which time contact can be manually reset. A second contact closes when the first contact opens.			*†§♣	X15A

- * Contact blocks not available for field conversion or replacement.
- ⊛ Minimum specified differential value approximately doubles.
- † **Manual reset devices cannot be supplied with an adjustable differential. Inherent differential is approximately three times the differential of the corresponding adjustable differential control.**
- § Available only for replacement of complete open type control in an existing Type 1 or 4 & 13 enclosure. Replacement in a Type 7 & 9 enclosure is not available because it would void UL and CSA.
- ♣ Type 7 & 9 enclosures for manual reset devices are not also rated Type 4 & 13.

Note: NEMA does not rate contacts to switch low voltage and current. Bulletin 836 Styles A and C Pressure Controls are supplied with silver contacts. The devices are designed to deliver high force snap action to the contacts. This provides exceptional contact fidelity at 24V DC I/O card current level entry when the control is protected in a suitable enclosure for the surrounding environment.

Ordering Modifications (cont'd)

Modifications are ordered by adding the appropriate modification suffix code to the catalog number of the basic device. Add suffix codes to the catalog number in descending order (highest number first).

Modifications

Modification	Description	Suffix Code
Oxygen/Nitrous Oxide Service	Bellows and fittings are specially prepared for oxygen and nitrous oxide service. The devices are tested with pure oxygen, bellows are plugged for protection from contamination, and a tag warning against contamination is applied.	X2
Tamper-Resistant Adjustment	Range and differential adjustment screws are designed so that after a setting has been applied to the control, the adjustment screws can be broken off with a pliers. Note: The "break-off" adjustment screw(s) will not be broken off unless a factory setting is given and the order specifies "Break-off Adjustment Screw(s)". See paragraph entitled "Factory-Set Temperature Controls" on page 13-18.	X4
Neon Pilot Light, 120V AC	A high intensity neon pilot light is available for 120V AC, 60 Hz applications and can be wired for ON or OFF operation. The current rating is 1.0 m A.*	X9
Red LED Pilot Light, 24V DC	A high intensity LED 24V DC pilot light is available to meet the requirements of the automotive, machine tool builders and other industries. The current rating is 22 mA and can be wired for ON or OFF operation.*	X15
Green LED Pilot Light, 24V DC	A high intensity LED 24V DC pilot light is available to meet the requirements of the automotive, machine tool builders and other industries. The current rating is 22 mA and can be wired for ON or OFF operation.*	X18
5-Pin Mini-Type Receptacle — No Pilot Light	Supplied with receptacle ready for field wiring.*	X42
5-Pin Mini-Type Receptacle — With Pilot Light	Supplied with receptacle and pilot light ready for field wiring. Pilot light suffix code X9 (120V AC Neon) or suffix code X15 or X18 (24V DC LED) must also be specified. See suffix codes X9 , X15 or X18 description above.*	X43
5-Pin Micro-Type Receptacle — No Pilot Light	Supplied with receptacle ready for field wiring.*	X142
5-Pin Micro-Type Receptacle — With Pilot Light	Supplied with receptacle and pilot light ready for field wiring. Pilot light suffix code X9 (120V AC neon) or suffix code X15 or X18 (24V DC LED) must also be specified. See suffix codes X9 , X15 or X18 description above.*	X143
Manual Test Button	Allows electrical testing of circuit — positive pressure setting only. Only available for standard, X221 and X321 contact blocks. See photo page 13-8 .	X47

* Not available on combined Type 7 & 9 and 4 & 13, Type 4X, and manual reset devices.

* Not available for combined Type 7 & 9 and 4 & 13 or Type 4X enclosures.

Accessories/ Replacement Parts

Ordering Accessories

Accessories are ordered as separate catalog numbers. Select the required accessories from the tables below.

Accessories

Pipe Adapter

Description	Cat. No.
1/4 in. male pipe adapter with copper seating washer for Style A only.	836-N1

Contact Block Replacement Kit

Description	Cat. No.
Kit consists of a standard contact block and instructions.	836-N2

Finger Safe Contact Block Cover

Description	Cat. No.
Clear contact block cover provides IP2X Finger Safe Protection.	41162-908-01

Hardware Kits for Mounting Open Type Controls in Special Enclosures

Description	Type	Material	Cat. No.
Hardware kits for mounting open type controls in special enclosures allow ease of connecting pressure lines to the enclosure. For use with Type 1 and Type 4 & 13 enclosures with wall thickness up to 0.25 in. (6.35 mm).	Style A Controls		
	Open type controls	Plated steel	836-N5
	Style C Controls		
	Open type controls	Brass	836-N8
Stainless steel		836-N10	

Angle Mounting Brackets

Description	Bracket Type	Cat. No.
For mounting one or two open type Bulletin 836 Style A Pressure Controls or Bulletin 837 Temperature Controls on an enclosure mounting plate.	Single bracket	836-N11
	Dual mounting bracket	836-N12

Steam and/or Corrosive Media Applications — Isolation Traps

Description	Type	Cat. No.
An isolation trap is available for high-temperature media applications from 150...600 °F or corrosive applications compatible with Type 316 stainless steel tubing and fittings. The isolation coil is inserted between the bellows of the pressure control and the elevated temperature line of the system. The isolation trap will fill with condensed water or can be filled with water or suitable fluid when installed. A silicone buffer fluid is available in a convenient dispenser. Copper alloy lower and higher pressure range bellows can be applied to many applications using the isolation trap. The silicone buffer fluid is used to isolate many corrosive substances from coming in contact with the bellows. The isolation trap is rated at 3000 psi working pressure. Not available for piston-type controls.	Isolation trap with two 1/4 in. male pipe fittings	836-N25
	Isolation trap with one 1/4 in. male and one 1/4 in. female pipe fitting	836-N26
	2 oz. of buffer fluid to fill bellows and tubing	836-N27



Isolation Trap and Silicone Buffer Fluid

Ordering Accessories

Accessories are ordered as separate catalog numbers. Select the required accessories from the tables below.

Accessories

External Fixed Pulsation Snubbers

Description	Type	Cat. No.
Controls are supplied as standard with an internal pulsation snubber. However, a control properly selected and used within the adjustable range values yet having a short bellows life is a good indication of the presence of extreme surge pressures. External fixed pulsation snubbers are available to provide additional dampening when extreme pulsations or surges are present. Recommended if more than eight line surges occur in a 24 hr. time period.	Snubber for Style A Controls	836-N6
	Snubber for Style C Controls	836-N7

Selectable Element Pulsation Snubbers

Description	Type	Cat. No.
Controls are supplied as standard with an internal pulsation snubber. However, a control properly selected and used within the adjustable range values, yet having a short bellows life, is a good indication of the presence of extreme surge pressures. Selectable element pulsation snubbers are supplied with five different elements to provide a selectable balance between maximizing pressure control life and minimizing control response time. Pulsation snubbers are supplied with the mid-range element already mounted and four other color-coded porosity elements included in the package.	Snubber for Style C Controls	836-N40

Selectable Pulsation Snubber Porosity Elements

Description	Recommended Type of Service	Color Code	Porosity	Cat. No.
Package consists of five porosity elements and complete instructions. Elements are color-coded for easy identification. Elements are available in five different porosities for a wide range of applications.	Viscous fluids (over 500 SSU)*	None		836-N43
	Medium type oils (225...500 SSU)*	Black		836-N44
	Water and light oils (30... 225 SSU)*	Brown		836-N45
	Low viscosity fluids (under 30 SSU)*	Green		836-N46
	Air and other gases	Red	Finer	836-N47
	One of each of the above	—	Assorted	836-N48

* SSU Saybolt Seconds Universal — units of viscosity measurement.

Note: Color code is located on end of element.

Pulsation Snubbers

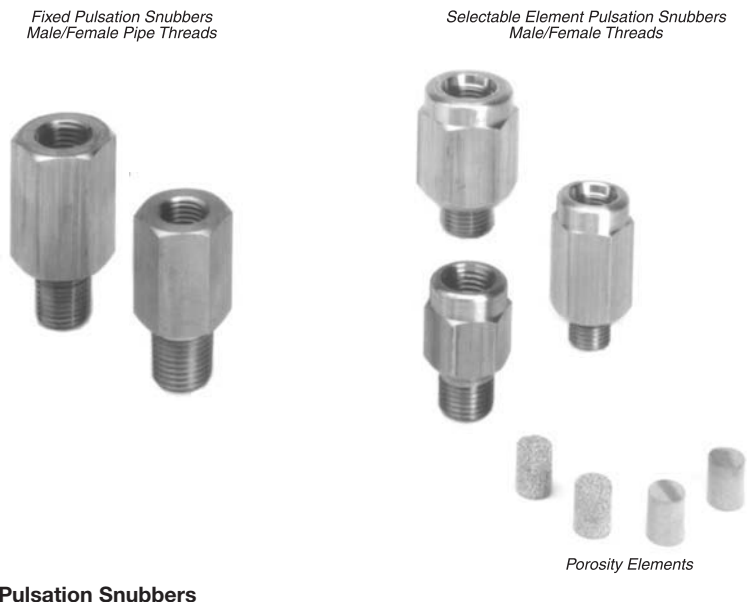

Pulsation Snubbers

Porosity Elements

Pressure Controls

Factory Options

Ordering Factory-Set Pressure Controls

- When a specific factory setting is requested, the specific terminal connections must be specified — e.g., N.O. or N.C. It must also be specified whether the contact operation is occurring on either increasing or decreasing pressure. For example:

Normally Closed (N.C.) contacts to open at* psi increasing pressure and close at* psi decreasing pressure.

—OR—

Normally Open (N.O.) contacts to close at* psi increasing pressure and open at* psi decreasing pressure.

- If minimum differential is not critical and the inherent minimum differential satisfies the application, specify the factory setting as follows:

Normally Closed (N.C.) contacts to open at* psi increasing pressure. Minimum differential.

—OR—

Normally Open (N.O.) contacts to close at* psi increasing pressure. Minimum differential.

- * Specify psi (pounds per square inch) or, in. Hg vacuum (inches of mercury vacuum)
- * Per ANSI B40.1 Grade 2A (0.5% accuracy full scale), Grade 3A (0.25% accuracy full scale).

If not specified, settings tolerances will be as shown in table below.

Pressure Range	Tolerance
30 in. Hg Vac....0 psi	+/- 1 in. Hg Vac.
> 0...100 psi	+/- 1 psi
> 100...300 psi	+/- 2 psi
> 300...500 psi	+/- 5 psi
> 500...1000 psi	+/- 10 psi
> 1000...5000 psi	+/- 50 psi

Standards Compliance

- UL 508
- UL 698 (Haz. Loc.)
- UL 1604 (Haz. Loc.)
- CSA 22.2 No. 14
- NEMA ICS-2
- IEC 529/IP2X

Certifications



File and Guide Numbers

	UL		CSA	
	File Number	Guide Number	File Number	Class
Bulletin 836	E14842	NKPZ	LR1234	3211-03
	E53048 (Haz. Loc.)	NOWT	LR11924 (Haz. Loc.)	3218-05
Hazardous Location enclosed devices are not CE compliant. All other enclosed devices are CE compliant.				

Quality analog “Test”[®] gauges are used when applying requested factory settings to these rugged industrial-grade pressure controls. (Gauges are calibrated and the accuracy is traceable to National Bureau of Standards.)

The actual requested setting is applied to the control by reading the set point directly from the test gauge being used. However, traceable gauge tolerance variance between source and user, and possible severe shock during shipping and installation, may contribute to the factory settings deviating slightly from the specified values. Slight recalibration can easily be accomplished upon final installation to meet specific requirements for the more demanding applications. When installed, the controls will perform with a repeat accuracy as established in the paragraph on page 13-8 entitled “Repeat Accuracy and Mechanical Life”.

Special service is available to factory set controls on Digital Laboratory Instruments, up to 600 psi, when required for the more critical applications. An additional charge may be added for this service contingent upon setting tolerance and quantity.

Consult your local Rockwell Automation sales office or Allen-Bradley distributor.

Two Style A Controls In One Enclosure

Bulletin 836 Style pressure controls which function independently may be mounted side by side in a single Type 1 enclosure. This design is ideal for installations where two controls would ordinarily be mounted. Each dual unit can be a combination of a Style A pressure control and a bulb and capillary type temperature control. See respective product tables.

To order this arrangement, specify the two desired catalog numbers in their mounted position within the dual enclosure to form a single catalog number. The list price is the sum of the two Type 1 enclosed devices.

For more information on special controls, please contact your local Rockwell Automation sales office or Allen-Bradley distributor.

Refrigeration Controls



Description

Bulletin 836 Refrigeration Controls are similar to Bulletin 836 Style A Pressure Controls. However, refrigeration controls are constructed with additional pulsation dampening to filter out the severe pulsations generated by reciprocating refrigeration compressors. Pressure controls not supplied with the added snubber function may result in reduced bellows life. The reduced life results from pulsations severe enough to cause the bellows to "squeal" at the pump frequency or at the harmonic wave generated at specific pump loading demands. Refrigeration controls are supplied as standard with the pulsation snubber built into the stem of the bellows.

Allen-Bradley heavy-duty refrigeration controls have copper alloy bellows for use with noncorrosive refrigerants. The devices can be supplied as single Open Type devices or mounted in a Type 1 enclosure. Standard controls have 7/16 in. – 20 SAE male threads for a 45° flare fuel and lubricant fitting. Optionally, the refrigeration controls can be supplied with capillary tubing. The capillary terminates with 1/4 in. tubing, which is flared and supplied with a 7/16 in. – 20 female nut. To modify the standard pressure connection, add suffix "-36" (denotes 36 in.) to the catalog number. There is no price addition for changing to a capillary-type pressure connection. Example: Cat. No. **836-H11-XHC**, modified for a 36 in. capillary connection, is Cat. No. **836-H11-XHC-36**.

Style H — High Pressure Refrigeration Controls



Style H

- Copper alloy bellows with built-in pulsation snubber
- 7/16 in. — 20 SAE male thread for 45° flare fitting
- Adjustable operating range — 30...120 psi
- Maximum line pressure — 450 psi
- Occasional surge pressure — 800 psi
- With capillary and flare connection

Style L — Low Pressure Refrigeration Controls



Style L

- Copper alloy bellows with built-in pulsation snubber
- With capillary and tubing connection
- Adjustable operating range — 20 in. Hg vacuum...120 psi
- Maximum line pressure — 220 psi

Style P — High Pressure Definite-Purpose Refrigeration Controls



Style P

- Copper alloy bellows with built-in pulsation snubber
- 7/16 in. — 20 SAE male thread for 45° flare fitting
- Operating range — 30...700 psi
- Line and occasional surge pressure — 800 psi
- Fixed differential — 30 psi

Pressure Controls

Style H, L, and P Refrigeration Controls — Copper Alloy Bellows



Style H High Pressure —
Copper Alloy, Open Type With Capillary
Adjustable Differential



Style L Low Pressure —
Copper Alloy, Open Type
Adjustable Differential



Style P High Pressure —
Copper Alloy, Open Type With Capillary
Fixed Differential

Style H High Pressure—Copper Alloy Bellows*

Pressure Specifications				Enclosure Type		Contact Reference Number (See table below)
Adjustable Operating Range [psi]	Adjustable Differential [psi] (Approximate Mid-Range Values)	Maximum Line Pressure [psi]	Limited Maximum Stop [psi]	Open Type Without Enclosure	Type 1	
				Cat. No.	Cat. No.	
30...270	30...80	600	—	836-H11-XHCS	836-H11-XHC	1
50...450	40...100	800	—	836-H11-BLCS	836-H11-BLC	1
100...285	40...90	600	285	836-H33-XKKS	836-H33-XKK	3
200...425	40...90	800	425	836-H33-BLKS	836-H33-BLK	3
125...280	60...120	800	280	836-H33-BKKS	836-H33-BKK	3
Customer Specified, Factory Locked Operating Range With Fixed Differential of 30 psi						
75...350	35	800	—	836-H33-XNAS	836-H33-XNA	3

Style L Low Pressure—Copper Alloy Bellows*

Pressure Specifications			Enclosure Type		Contact Reference Number (See table below)
Adjustable Operating Range [in. Hg Vacuum...psi]	Adjustable Differential [psi] (Approximate Mid-Range Values)	Maximum Line Pressure [psi]	Open Type (Without Enclosure)	Type 1	
			Cat. No.	Cat. No.	
20 in. Hg Vacuum...120 psi	5...30*	220	836-AL11-NKCS	836-AL11-NKC	1
20 in. Hg Vacuum...120 psi	9...50*	220	836-AL32-NKCHS	836-AL32-NKCH	2

Style P High Pressure Definite Purpose—Copper Alloy Bellows*

Pressure Specifications				Enclosure Type		Contact Reference Number (See table below)
Adjustable Operating Range [psi]	Fixed Differential [psi]	Maximum Line Pressure [psi]	Limited Maximum Stop [psi]	Open Type (Without Enclosure)	Type 1	
				Cat. No.	Cat. No.	
30...700	30	800	—	836-P11-ARBS	836-P11-ARB	1

Contact Reference Number Table

Reference Number	Description	Symbol	Rating
1	Single pole double throw — automatically opens or closes on rise or fall.		Non-inductive: 5 A, 240V ... 3 A, 600V Control Circuit Rating: AC-125VA, 24...600V DC-57.5VA, 115...230V
2	Single pole single throw, normally open — closes on rise.		1 Hp, 115V AC 1.5 Hp, 230V AC Control Circuit Rating: AC-600VA, 110...600V DC-57.5VA, 110...250V
3	Single pole single throw, normally closed — opens on rise.		

* Copper alloy bellows may be used on water or air, and other liquids not corrosive to this alloy.

* To determine differential in in. Hg vacuum, multiply the value in the table by 2.036 (or approximately 2).

Factory Options for Refrigeration Controls

Two Controls In One Enclosure

It is common in the industry to supply a low-pressure **Style L** and a high-pressure **Style H** mounted in a common, dual Type 1 enclosure. This factory option can be supplied with the low-pressure control on the left and the high-pressure control on the right. To order, combine the two desired Type 1 catalog numbers into a single number. Example: Low-pressure control **836-AL11-NKC-36**, plus high-pressure control **836-H11-BLC-36**, becomes an **836-AL11-NKC-36/836-H11-BLC-36**.



Two Style A Pressure Controls in One Type 1 Enclosure

Approximate Dimensions and Shipping Weights

Dimensions in inches (millimeters). Dimensions are not intended to be used for manufacturing purposes.

Style A

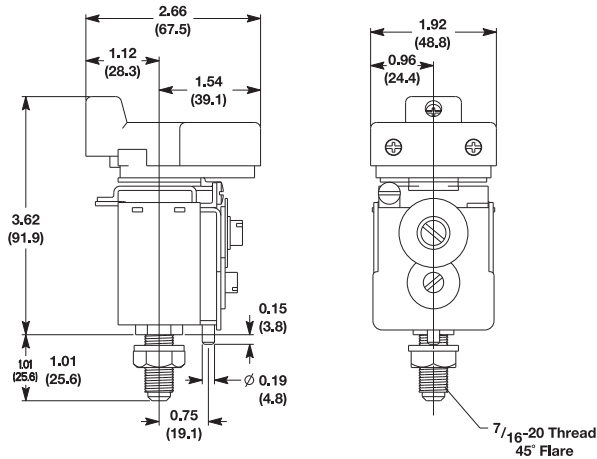

Open Type
Approximate Shipping Weight 1 lb. (0.45 kg)

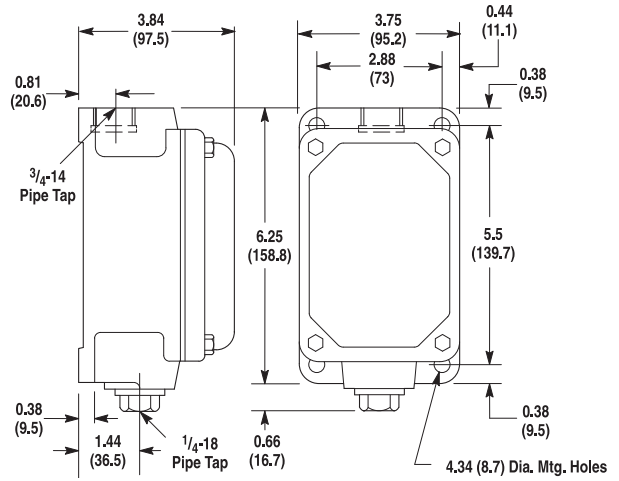

Type 7 & 9 and 4 & 13
Approximate Shipping Weight 9 lbs (4.1 kg)

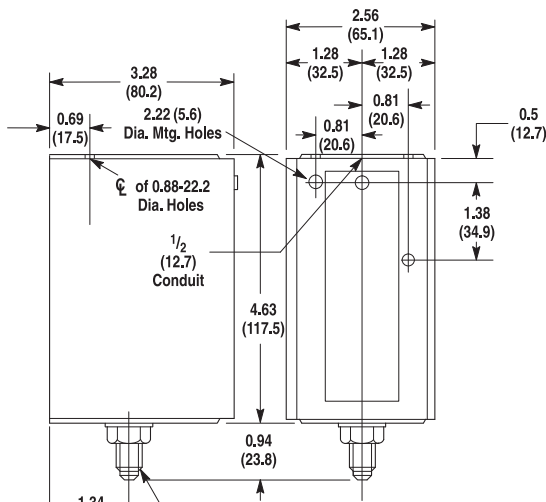

Type 1
Approximate Shipping Weight 2 lbs (0.91 kg)

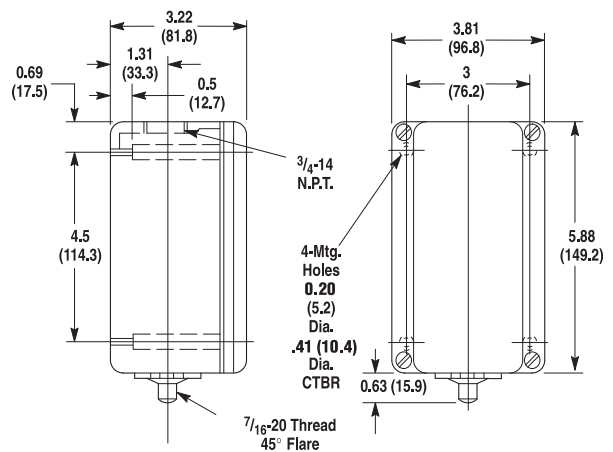

Type 4 & 13
Approximate Shipping Weight 3 lbs (1.4 kg)

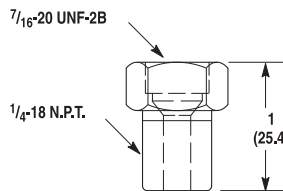

Cat. No. 836-N1
Approximate Shipping Weight 1/4 lb (0.1 kg)

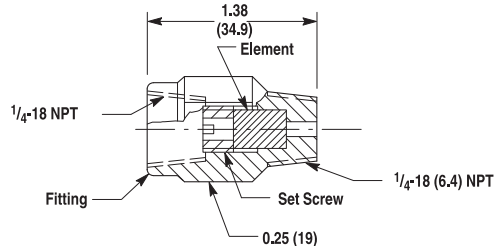

Cat. No. 836-N40
Approximate Shipping Weight 1/4 lb (0.1 kg)

Approximate Dimensions and Shipping Weights

Dimensions in inches (millimeters). Dimensions are not intended to be used for manufacturing purposes.

Style C

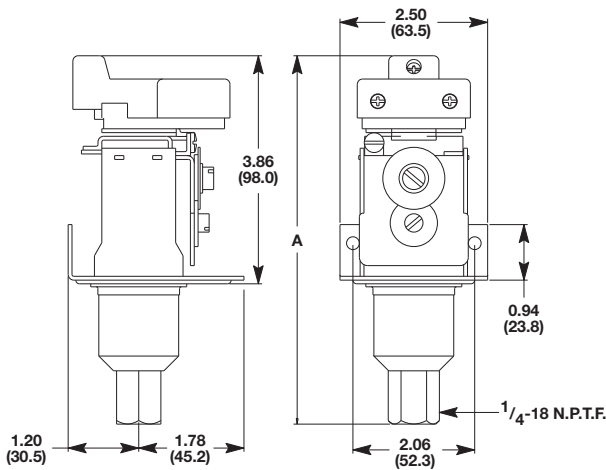

Open Type
 Approximate Shipping Weight 1.3 lbs. (.60 kg)*

Cat. No.	Dimension A
C2, C3, C60, C61	6.11 (155)
C4	5.99 (152)
C5, C64	5.94 (151)
C6, C62	6.29 (160)
C7, C63	6.24 (158)
C8, C9	5.56 (141)
C10, C11, C12, C65	5.78 (147)

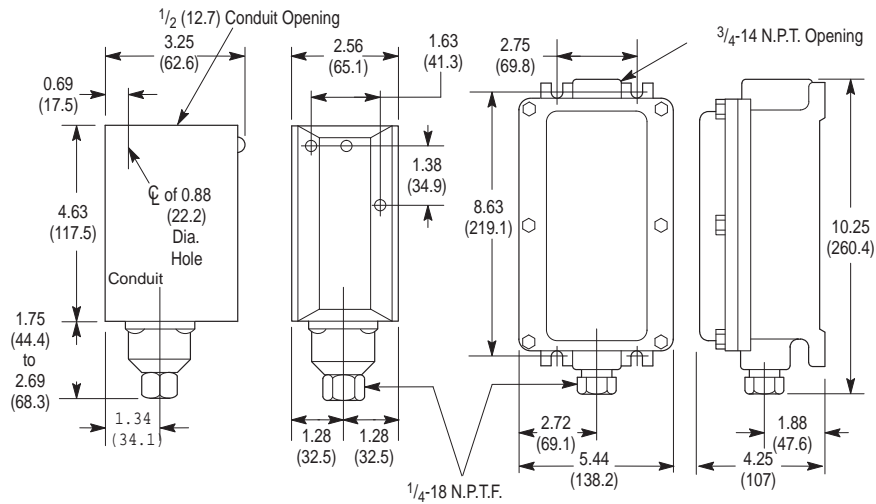

Type 1
 Approximate Shipping Weight 2.0 (.9 kg)

Type 7&9 and 4&13
 Approximate Shipping Weight 10 lbs. (4.5 kg)

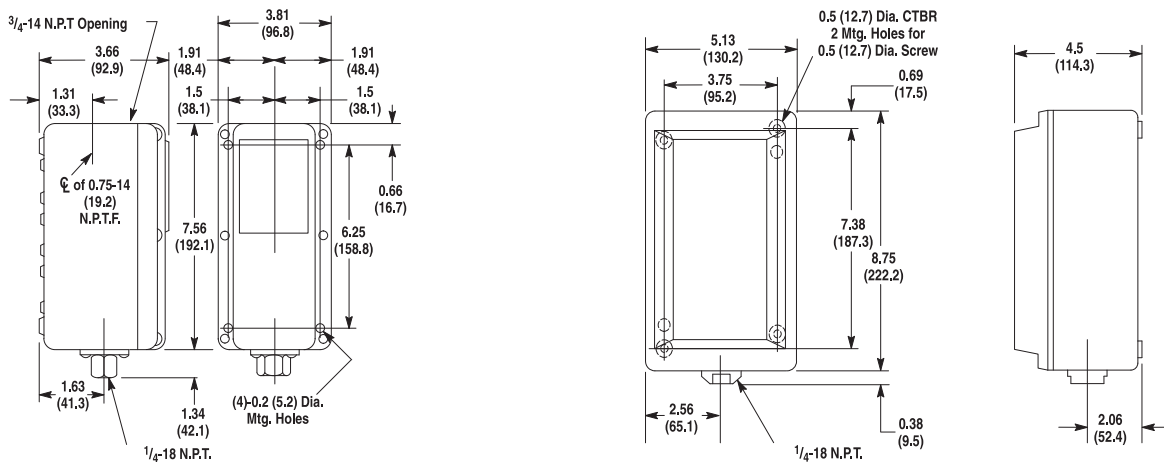

Type 4 & 13
 Approximate Shipping Weight 5 lbs (2.3 kg)

Type 4X
 Approximate Shipping Weight 6 lbs (2.7 kg)

* Cat. No.s 836-C1 and 836-C1A require a 2 in. swing radius from centerline of pressure connection. Mount control on 7/8 in. minimum spacers.



Bulletin 836T Pressure Controls

- Operating ranges from 30 in. Hg vacuum...5000 psi
- Independently adjustable range and differential
- Copper alloy and stainless steel bellows
- 2- and 4-Circuit contact block
- Pressure difference controls available
- 1/4 in. and 3/8 in. N.P.T. and O-ring straight thread connections
- Type 4 & 13 and Type 7 & 9 and 4 & 13 combination enclosures

Table of Contents

Product Overview this page
 Technical Data 13-26
 Product Selection 13-34
 Modifications 13-41
 Accessories 13-42
 Conversion Kits 13-43
 Factory Options 13-44
 Wiring Diagrams 13-45
 Approximate Dimensions 13-48

Standards Compliance and Certification

(For file and guide numbers, see page 13-44)



Product Overview

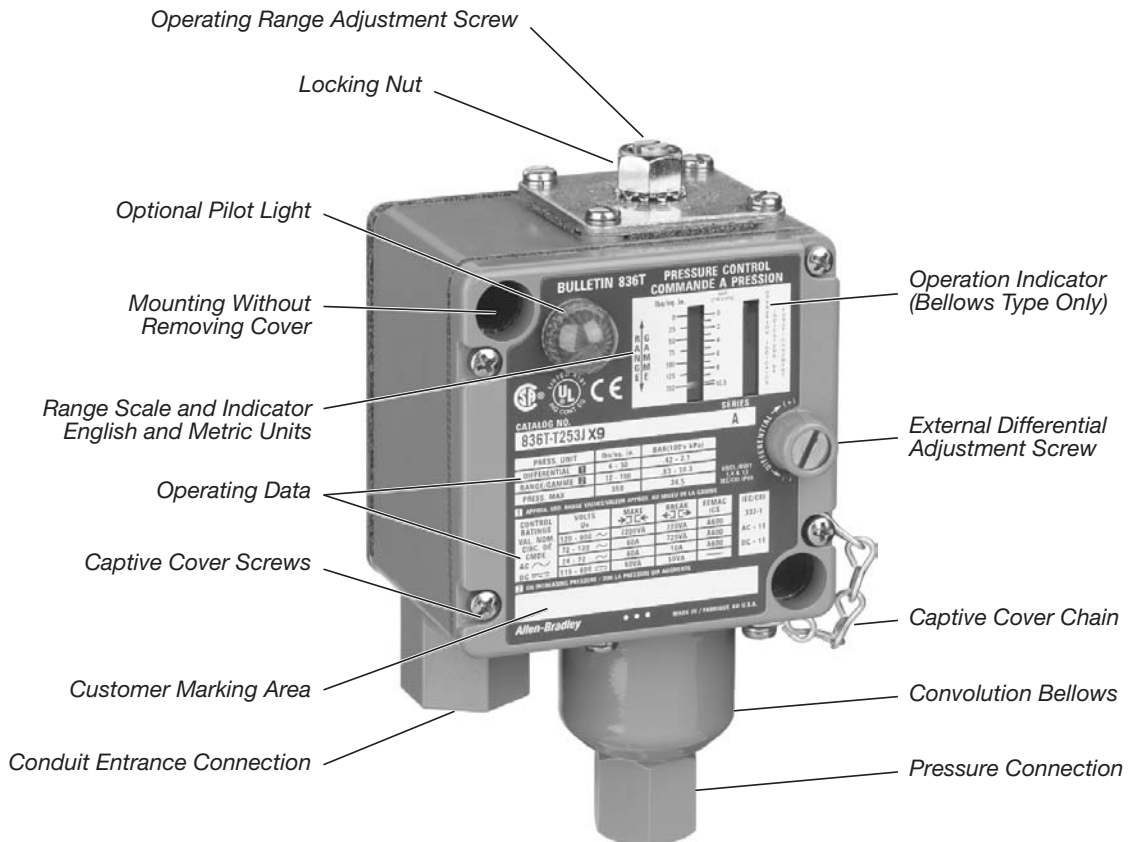

Bulletin 836T Style T Bellows Type Enclosure Type 1, 4 & 13, IEC IP66

Description

Bulletin 836T Pressure Controls are control circuit devices designed to meet the traditional requirements of the transportation, machine tool, and other heavy-duty industries. Allen-Bradley Bulletin 836T Pressure Controls can be used in pneumatic and hydraulic applications. The copper alloy bellows actuators can be used with air, water, oil, vapor, and other non-corrosive gases and liquids. Type 316 stainless steel bellows are available for more corrosive gases, vapors, and fluids.

A rugged stainless steel cylinder and stainless steel piston assembly is used for the higher-pressure coolant and hydraulic oil applications. May also be used with water and water-based fluids. The controls feature snap-action precision switches equipped with silver contacts. A relatively friction-free mechanism provides consistent operation regardless of mounting position. Devices are designed to allow easy adjustment of pressure settings.

Allen-Bradley Bulletin 836T Pressure Controls are used in many types of applications with adjustable ranges from 30 in. Hg vacuum...5000 psi. They can be used to control pneumatic systems and maintain a pressure tank within a preset and constant pressure range. They can be used to detect over-pressures of gases and liquids to prevent damage to valuable equipment. Pressure controls can also detect low pressure to protect equipment from loss of coolants and lubrication.

Bulletin 836T Pressure Controls are offered in a variety of styles to fit a wide range of applications. The devices are available with either a Type 1, 4 & 13, or 7 & 9 and 4 & 13 combined enclosure. They are available with two-circuit or four-circuit contact blocks. Accessories and modifications are available to tailor the devices to meet most application requirements.

Style T — Pressure Control



Style T

- Independently adjustable operating range and differential
- Single bellows or piston operation

Copper Alloy Bellows

- 1/4 in. N.P.T. female pipe connection
- Adjustable operating range — 30 in. Hg vacuum...650 psi
- Maximum line pressure — up to 1300 psi
- Occasional surge pressure — up to 1600 psi

Type 316 Stainless Steel Bellows

- 1/4 in. N.P.T. female pipe connection
- Adjustable operating range — 30 in. Hg vacuum...375 psi
- Maximum line pressure — up to 600 psi
- Occasional surge pressure — up to 600 psi

Piston

- 3/8 in. N.P.T. female pipe connection
- SAE 7/16-20 UNF-2B thread O-ring boss seal
- SAE 9/16-18 UNF-2B thread O-ring boss seal
- Adjustable operating range — 40...5000 psi
- Occasional surge pressure — up to 15,000 psi

Applications

- Machine tools
- Machine hydraulic pressures
- Material clamping fixtures
- Lubricant and coolant pressures
- Compactor ram pressures
- Air compressors

Style D — Pressure Difference Control



Style D

- Independently adjustable system difference range and differential
- Two-bellows operation, one bellows connected to each system

Copper Alloy Bellows

- 1/4 in. N.P.T. female pipe connection
- Adjustable system difference range — 1...70 psi
- Maximum line pressure — up to 600 psi
- Occasional surge pressure — up to 650 psi

Type 316 Stainless Steel Bellows

- 1/4 in. N.P.T. female pipe connection
- Adjustable system difference range — 1...70 psi
- Maximum line pressure — up to 500 psi
- Occasional surge pressure — up to 500 psi

Technical Terms

Adjustable operating range — Total span within which the contacts can be adjusted to trip and reset.

Trip setting — Higher pressure setting at which value the contacts transfer from their normal state to a change state.

Reset setting — Lower pressure setting at which value the contacts return to their normal state.

Adjustable differential — Difference between the trip and reset values

Minimum differential — When the differential is set to the lowest possible difference between trip and reset.

Maximum differential — When the differential is set to the highest possible difference between trip and reset.

Max. occasional surge pressure — Maximum surge pressure that can be applied to the actuator. Surges or ransients can occur during start-up and shut-down of a machine or system. Expressed in milliseconds, complex electronic instrumentation is required to measure the varying amplitude, frequency, and duration of this wave form. Extreme surges that occur approximately 8 times in a 24-hour period are negligible.

Maximum line pressure — Maximum sustained pressure that can be applied to the actuator without permanent damage. The control should not be cycled at this pressure. **Note:** Does not apply to piston type controls.

psi — Pounds per square inch gauge (positive pressure). Devices listed are in gauge pressure units which use atmospheric pressure as a reference. Atmospheric pressure at sea level is approximately 14.7 psi or 30 in. Hg.

Vacuum — Inches of mercury (in. Hg) vacuum (negative pressure).

Operating range adjustment screw — This screw is used to adjust the trip setting by varying the force of the main spring.

Differential adjustment screw — This screw is used to adjust reset setting by varying the force of the differential blade spring.

Pressure media — There are many types of pressure media that can be controlled. Examples include air, water, hydraulic fluids, and other types of gases and liquids. The type of media and the maximum system pressure will determine the type of actuator used for the pressure control application. See page 13-33.

Pressure connection — Common standard types of pressure connections used in control systems are 1/4 in. and 3/8 in. N.P.T. female pipe threads. SAE 7/16 and SAE 9/16 O-ring boss seals are also available (piston versions only).

Contact configuration — Bulletin 836T controls are available with either a 2-circuit or 4-circuit contact block. See page 13-31.

Style D

Style D — pressure difference controls adjustable system difference range — The adjustable operating range for a pressure difference control.

System difference pressure bushing — This bushing is used to adjust the trip setting by varying the force on the main spring.

Trip setting — Desired difference in pressure between the two bellows at which value the contacts transfer from their normal state to a changed state. This occurs in one of the following conditions:

- The pressure in the bottom bellows is higher than the pressure in the top bellows by a value equal to the trip setting.
- The pressure in the bottom bellows remains constant and the pressure in the top bellows decreases by a value equal to the trip setting.

Reset setting — Predetermined normal difference in pressure between the two bellows, at which value the contacts return to their normal state. This occurs in one of the following conditions:

- The pressure in the bottom bellows is lower than the top bellows.
- The pressure in the bottom bellows remains constant and the pressure in the top bellows increases.

Figure 1
 Graphics to illustrate technical terms

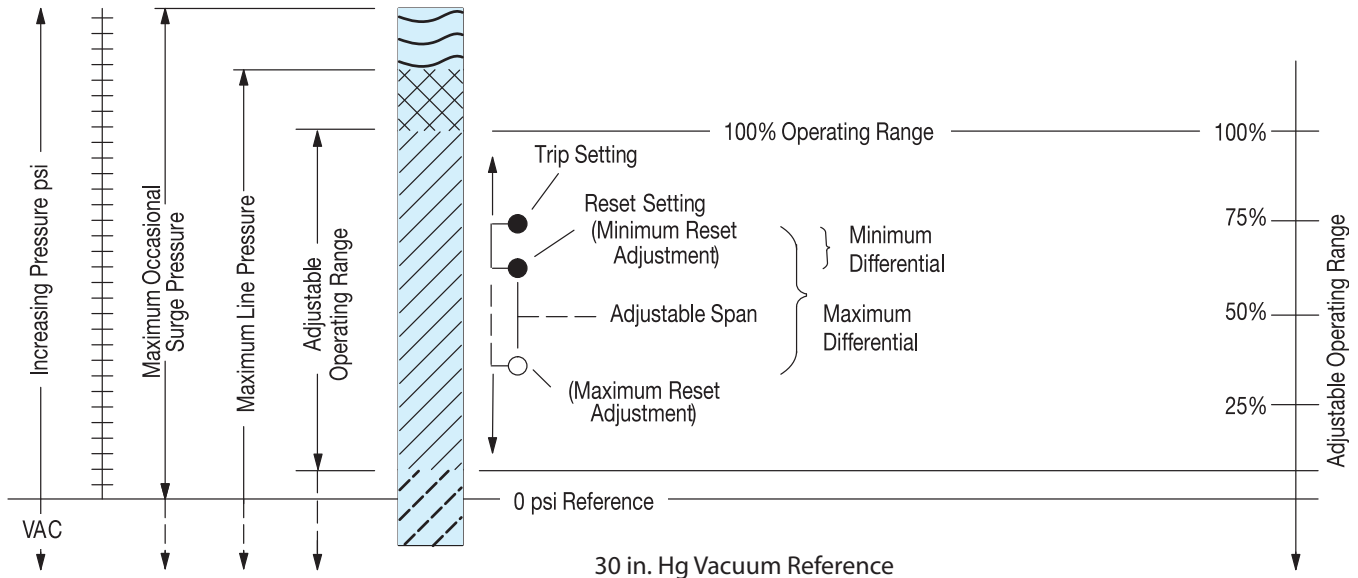

Theory of Operation

Bulletin 836T Pressure Controls are designed to open or close electrical circuits in response to changes in pneumatic (air or gas) or hydraulic (oil or non-corrosive liquids) pressure. Piston controls are not intended for use with air or water. Figure 2 shows the basic operating mechanism.

Pressure is applied to the actuator which can be either a bellows or piston type. As pressure rises, the actuator exerts force on the main spring. When the threshold force of the main spring is overcome, levers transfer the motion to the contact block, displacing the contacts — this is referred to as the trip setting. The unique lever design amplifies the actuator motion, providing shorter stroke, which results in maximizing bellows life.

The lever assembly also includes a virtually friction-free over-center toggle arrangement, providing positive snap action to the contact block for long contact life. As pressure falls, force on the differential spring increases and contacts return to their normal state — this is referred to as reset setting. Varying the force of the main spring (by turning the operating range adjustment screw) determines when the contacts will trip. Varying the force of the differential spring (by turning the differential adjustment screw) determines when the contacts will reset. Setting trip and reset values determines the operating parameters of the application.

Figure 2
 Basic mechanical structure

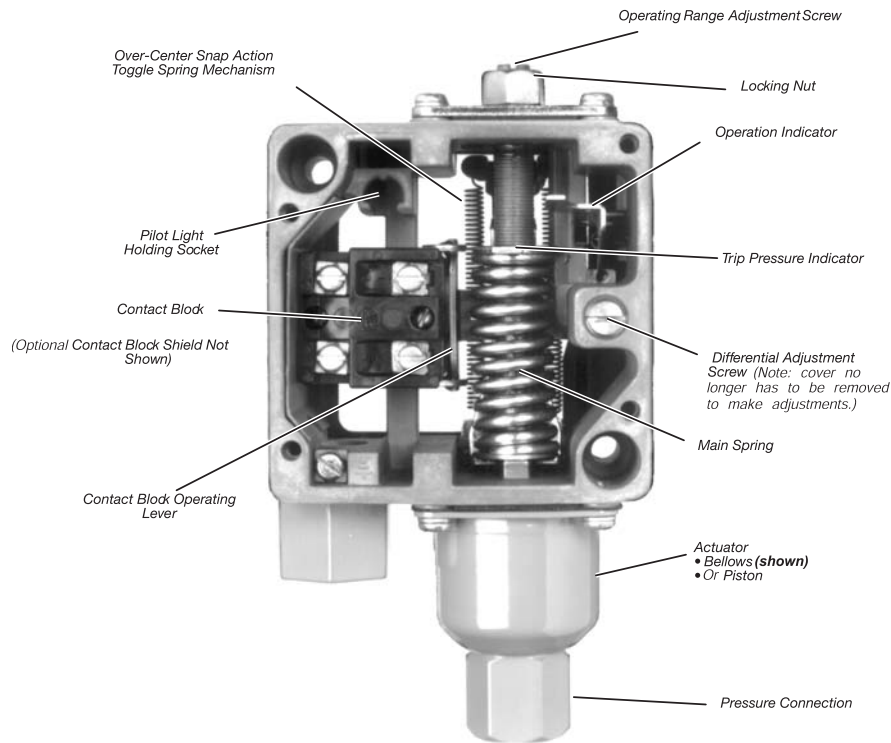

Applications for Control

Pressure controls can be used to either control or monitor a machine or process. Figure 3 shows a typical control application. Here, pressure is controlled within predetermined high and low values. Figure 4 shows a typical monitoring application. Here, pressure is monitored between a high and low value, signaling when a preset limit has been exceeded.

Figure 3
 Typical control application

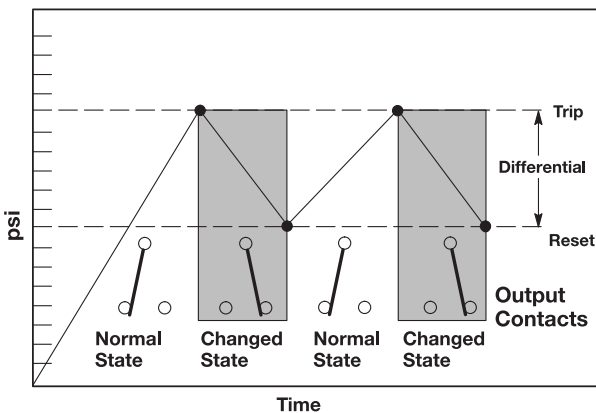
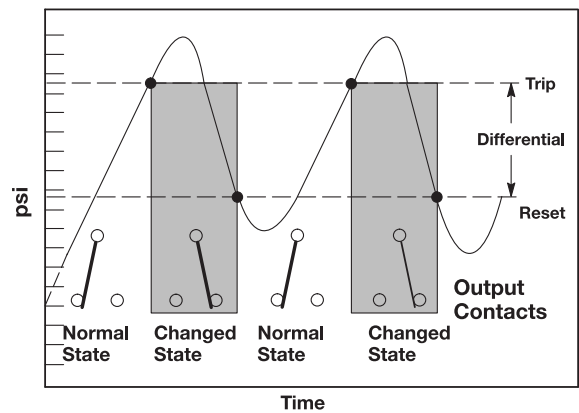

Figure 4
 Typical monitoring application



Pressure Controls

Technical Data, Continued

Control Setting — Style T Pressure Controls

Allen-Bradley controls are designed for ease of setting to help minimize installation time. Standard pressure controls shipped from the factory are set at the maximum operating range and minimum differential. By using a pressure gauge and following these simple directions, the control can be set to the specific requirements for each application. See Figure 5.

Step 1 — Adjust trip setting

The trip setting is controlled by the operating range adjustment screw and is adjusted externally. After loosening the lock nut, the trip setting is set by turning the operating range adjustment screw counterclockwise to lower the trip setting or clockwise to raise the trip setting. The approximate trip setting is shown on the indicating scale. When the proper setting is reached, simply tighten the lock nut.

Note: Turning the operating range adjustment screw will cause both the trip and reset settings to change in virtually equal increments.

Step 2 — Adjust reset setting

The reset setting is controlled by an external differential adjustment screw. The reset setting is set by turning the differential adjustment screw clockwise to increase the differential or counterclockwise to decrease the differential.

Note: Adjusting the differential has little or no affect on the trip setting.

Figure 5

Trip and reset adjustment for pressure controls

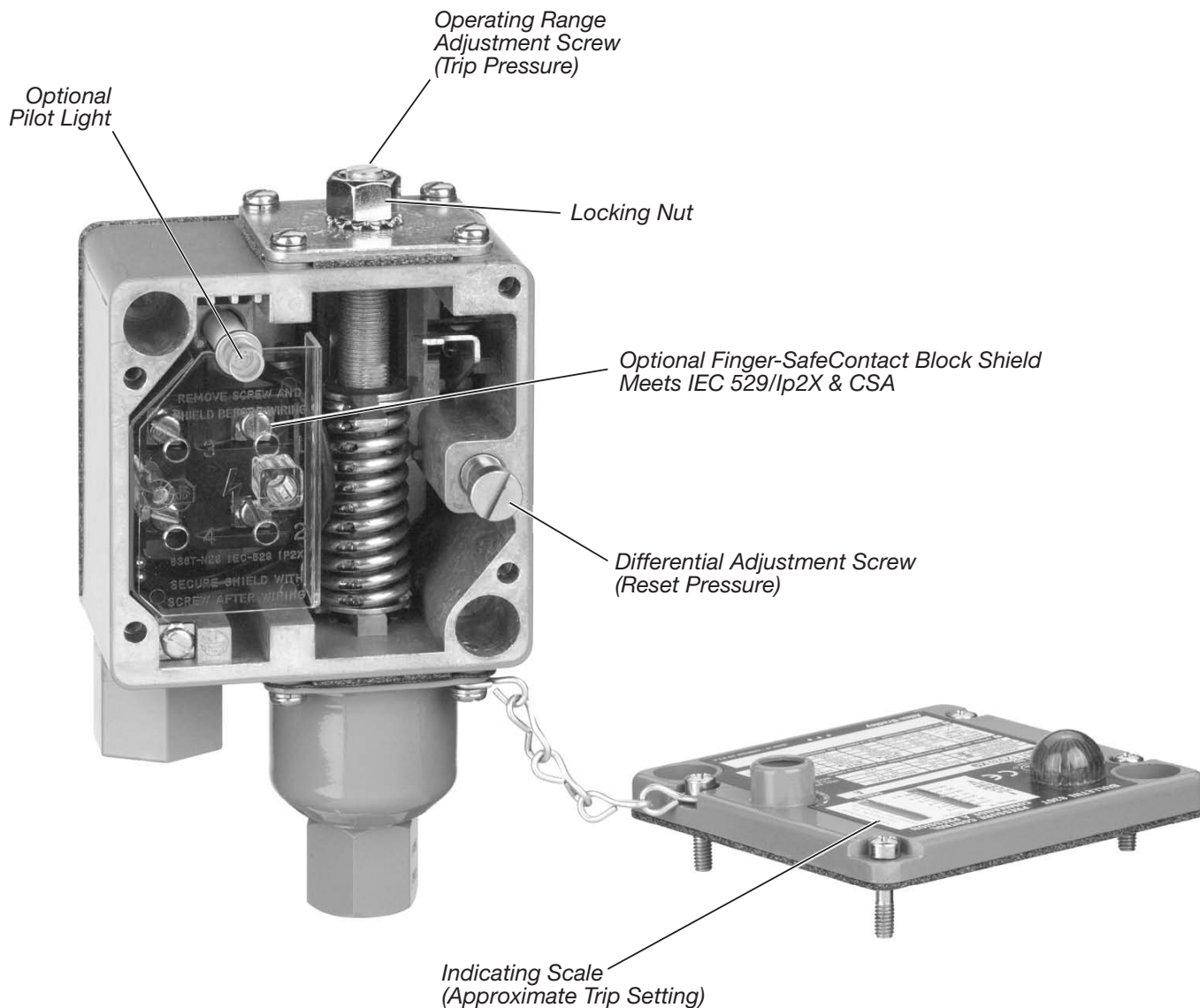

Control Setting — Style D Pressure Difference Controls

Standard pressure difference controls shipped from the factory are set at the maximum adjustable difference range and minimum differential. Remove the front cover and use a pressure gauge to make the following adjustments. See Figure 6.

Step 1 — Adjust trip setting (difference pressure)

The trip setting is controlled by the system difference pressure bushing and is adjusted internally. With no pressure (open to atmosphere) applied to top bellows, apply a constant pressure to bottom bellows equal to the desired difference in pressure at which the contacts are to trip. Insert a 1/8 in. diameter rod into a hole in the bushing and turn bushing to the left. Continue to turn bushing until the mechanism trips; circuit 1-2 will open. At this value, the trip setting is set at the pressure which is being applied to the bottom bellows.

Note: Turning the system difference pressure bushing will cause both the trip and reset settings to change in virtually equal increments.

Step 2 — Adjust reset setting (differential pressure)

The reset setting is controlled by differential adjustment screw (this adjustment can be made with the cover on). The reset setting is adjusted by turning the differential adjustment screw clockwise to increase the differential or counterclockwise to decrease the differential.

Note: Adjusting the differential has little or no affect upon the trip setting (difference pressure).

Figure 6

Trip and reset adjustment for pressure difference controls — 4-circuit contact block

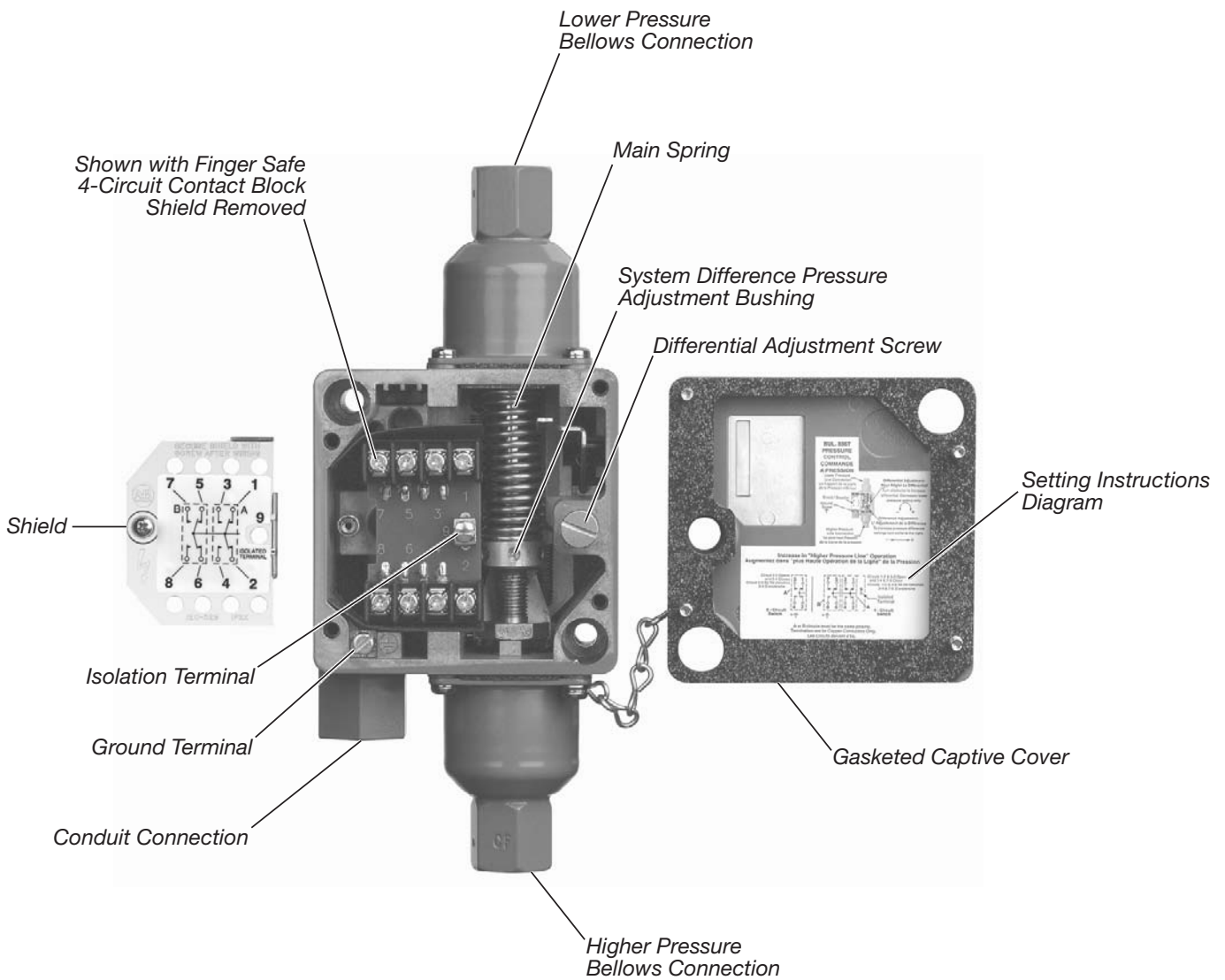

Repeat Accuracy and Mechanical Life

The design and construction of Bulletin 836T Pressure Controls provide a typical repeat accuracy equal to or better than the values shown in the repeat accuracy table below. Repeat accuracy is based on percent of maximum range, evaluated from test data and calculated using the formula per ICS 2-225 standards. Repeat accuracy and mechanical life of bellows type controls is graphically illustrated in Figure 7. The life curve does not apply to piston type controls.

For general applications, controls selected where the contacts operate between 30% and 80% of the operating range and where the maximum line and surge pressures do not exceed the specified values will provide excellent life and repeat accuracy. For more specific applications, it is important to note that the controls are designed to operate below or above these values. However, there may be a small trade-off between the factors of repeat accuracy and mechanical life.

Figure 7
Repeat accuracy versus mechanical life graph

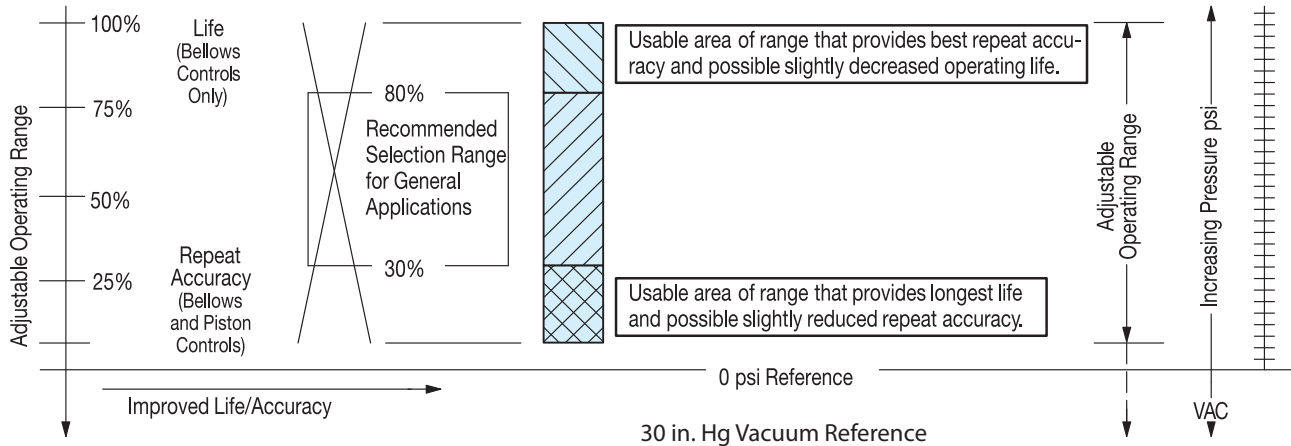

Repeat Accuracy

Type	Typical Characteristics (% of Maximum Range) *
Bellows	± 1%
Piston with seal	± 5% †
Piston without seal	± 3%

* Evaluation made from test data and calculated using formula per ICS 2-225 standards.

† Seal adds additional friction and value shown takes into consideration initial breakaway frictional force incurred during start-up or infrequent cycle operation. On continual cycle operation the repeat accuracy approaches ±3%.

Conversion Factors (Rounded)

psi x 703.1 = mm/H₂O
 psi x 27.68 = in. H₂O
 psi x 51.71 = mm/Hg
 psi x 2.036 = in. Hg
 psi x 0.0703 = kg/cm²
 psi x 0.0689 = bar
 psi x 68.95 = mbar
 psi x 6895 = Pa
 psi x 6.895 = kPa

Note: psi - pounds per square inch (gauge).
 H₂O at 39.2 °F
 Hg at 32 °F

Mounting without Removing Cover

Bulletin 836T controls can be mounted without removing the front cover. This helps prevent foreign materials from entering the opened enclosure during the interval between mounting and wiring of the control.

Factory Set Pressure Controls

Rockwell Automation will factory set pressure controls to customer specified values. Unspecified pressure controls shipped from the factory are set at the maximum operating range and minimum differential. See Factory-Set Pressure Controls, page 13-44.

Temperature Range

The temperature range at +32 °F (0 °C) or below is based on the absence of freezing moisture, water, or other fluids that may solidify and impede the operation of the control. Temperature ratings:

Operating: -22... +150 °F
 (-30...+66 °C)
 Storage: -22...+200 °F
 (-30...+93 °C)



Contacts

Bulletin 836T controls feature 2- and 4-circuit contact blocks for added control circuit flexibility. Two-circuit contact blocks have one normally open contact and one normally closed contact and may be arranged for single-pole double-throw operation or separate circuit operation having the same polarity. Four-circuit contact blocks may be arranged for double-pole double-throw operation or separate circuit operation having the same polarity.

2-Circuit Contact Ratings — NEMA A600 (ICS 2-125)

Maximum AC Voltage	AC				DC		
	A		Continuous Carrying Current	VA		Maximum Voltage	[A]
	Make	Break		Make	Break		
120	60	6.00	10	7200	720	115...125	0.4
240	30	3.00	10	7200	720	230...250	0.2
480	15	1.50	10	7200	720	550...600	0.1
600	12	1.20	10	7200	720	—	—



IEC 337-1

Maximum Operational Voltage U_e	Utilization Category	Maximum Continuous Current I_{th}	Volts U_e	Rated Operational Current	
				Make	Break
					
AC600	AC-11	10	120...600 AC	7200 VA	720 VA
		10	72...120 AC	60 A	720 VA
DC600	DC-11	10	24...72 AC	60 A	10 A
		—	115...600 DC	50 VA	50 VA

4-Circuit Contact Ratings — NEMA B150 (ICS 2-125)

Maximum AC Voltage	AC				DC		
	A		Continuous Carrying Current	VA		Maximum Voltage	[A]
	Make	Break		Make	Break		
120	30	3.00	5	3600	360	115...120	0.33
240	27.5	2.80	5	6600	660	230...240	0.17

IEC 337-1

Maximum Operational Voltage U_e	Utilization Category	Maximum Continuous Current I_{th}	Volts U_e	Rated Operational Current	
				Make	Break
					
AC150	AC-11	5	72...120 AC	30 A	360 VA
		5	24...72 AC	30 A	3 A
DC150	DC-11	—	115...240 DC	40 VA	40 VA

Note: NEMA does not rate contacts to switch low voltage and current. Bulletin 836T Styles T and D Pressure Controls are supplied with silver contacts. The devices are designed to deliver high force snap action to the contacts. This provides exceptional contact fidelity at 24V DC I/O card current level entry when the integrity of the enclosure is maintained.

Contact Wiring Configurations

2-Circuit Contact Blocks

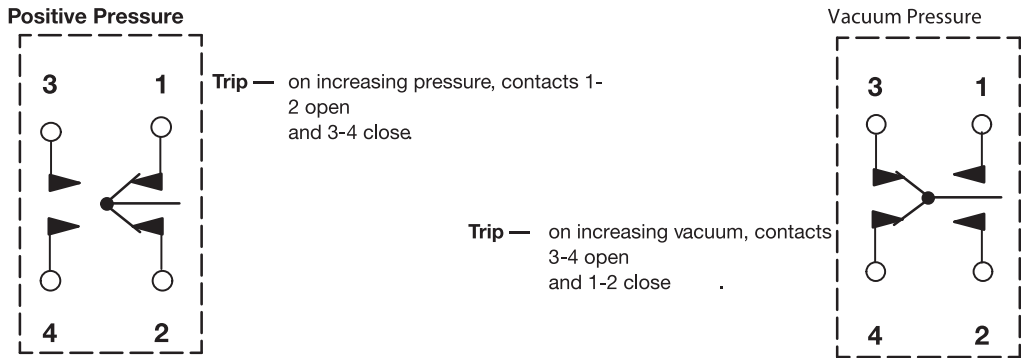

4-Circuit Contact Blocks

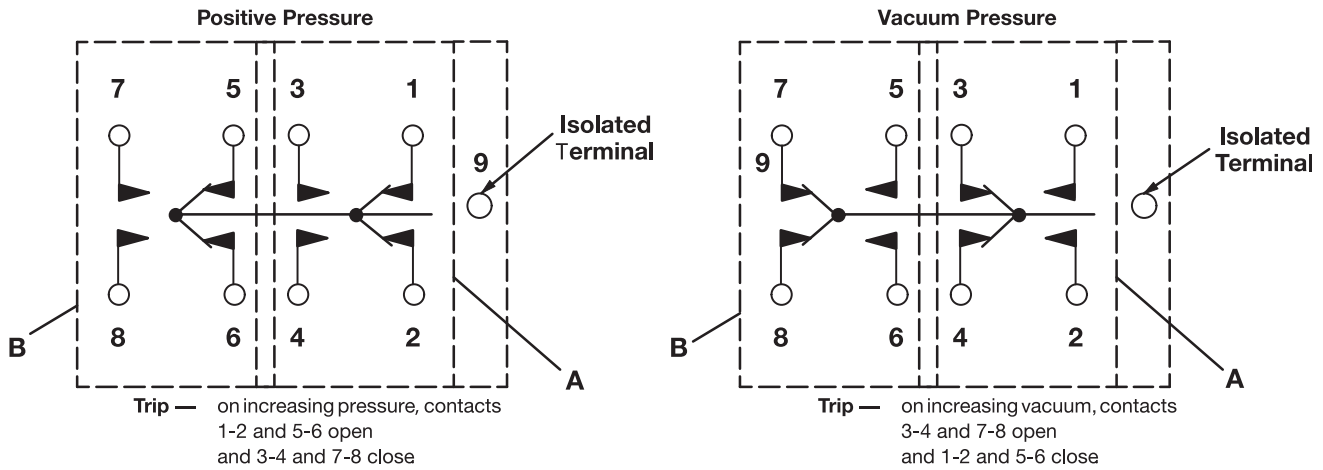

Note: Circuits A and B are electrically isolated from one another.
A or B circuits must be the same polarity.

Nameplate with Removable Paint Mask

The masks are convenient for the many users who repaint controls to match the machine or color code equipment. Saves costly time-consuming hand masking necessary so as not to conceal product functional specifications and approval listings. This feature is standard on most controls at no additional cost. The paint mask feature cannot be supplied on controls with pilot lights. They are also not available on those devices where it is necessary to remove the mask and add suffix modifications to the catalog number or specific customer identification in the space provided.

Figure 8
 Removable paint mask



Cover with Transparent Mask and Instruction Label in Place

Cover with Mask Partially Removed

Pressure Control Selection

The selection table below is an overview of the five types of Bulletin 836T Pressure Controls Rockwell Automation offers. Each type of control is suitable for use on many types of applications. Pressure ranges, pressure connections, enclosure types, and the compatibility of the actuator with different types of pressure media are given to assist in the selection of which type of control to use.

836T				
Actuator Type	Copper Alloy Bellows	Type 316 Stainless Steel Bellows	Piston Type Without Seal	Piston Type With Seal
Adjustable operating ranges	30 in. Hg vacuum...650 psi	30 in. Hg vacuum...375 psi	40...5000 psi	80...5000 psi
Adjustable differentials	2...125 psi	2...90 psi	20...650 psi	40...650 psi
Maximum line pressures	up to 1300 psi	up to 600 psi	—	—
Occasional surge pressures	up to 1600 psi	up to 600 psi	up to 15,000 psi	up to 15,000 psi
Pressure Media				
Air	•	•		
Water	•	•	•	•
Hydraulic fluids	•	•	•	•
Corrosive liquids *		•		
Non-corrosive liquids	•	•	•	•
Corrosive gases *		•		
Non-corrosive gases	•	•		
Enclosures				
Type 1, 4 & 13	•	•	•	•
Type 7 & 9 and 4 & 13, IP66	•	•	•	•
Pipe Connections				
Standard pressure connection	1/4 in. N.P.T. female pipe thread	1/4 in. N.P.T. female pipe thread	3/8 in. N.P.T. female pipe thread SAE 7/16-20 UNF-2B thread O-ring boss seal SAE 9/16-18 UNF-2B thread O-ring boss seal	3/8 in. N.P.T. female pipe thread SAE 7/16-20 UNF-2B thread O-ring boss seal SAE 9/16-18 UNF-2B thread O-ring boss seal

* Corrosive liquids and gases must be compatible with Type 316 Stainless Steel Bellows.

Note: Pressure difference controls are supplied with either copper alloy or stainless steel bellows. See Product Selection on page 13-39 and page 13-40 for details.

Ordering Bulletin 836T Pressure Controls

When ordering Bulletin 836T Pressure Controls, consider the following:

- Device style
- Adjustable operating range
- Adjustable differential
- Maximum line pressure
- Occasional surge pressure
- Pressure media
- Enclosure type
- Pressure connection

How to Order

Step 1: Basic Device

Select a catalog number for the basic device.....**See pages 13-35...13-40.**

Step 2: Modifications

If required, add the appropriate modification suffix code(s) to the catalog number of the basic device.....**See page 13-41.**

Step 3: Accessories

If required, order accessories.....**See page 13-42.**

Step 4: Factory Options

Factory-set pressure controls.....**See page 13-44 .**

Catalog Number Explanation

Note: Catalog number must not include blank spaces.

836T – T 25 1 J X40 X15
a b c d e f

a

Style of Device	
Code	Description
T	Pressure control
D	Pressure difference control

c

Pressure Specifications	
See "Pressure Specifications" on pages 13-35...13-40	

e

Contact Block Type	
Code	Description
None	2-circuit contact block - standard
X40	4-circuit contact block

b

Operator Type		
Code	Style	Description
25	T	Copper alloy bellows
26	T	Type 316 stainless steel bellows
30	T	Piston without seal
35	T	Piston with seal
40	T	Piston with seal (independent trip and reset adjustment)
45	D	Copper alloy bellows
46	D	Type 316 stainless steel bellows

d

Enclosure Type	
Code	Description
J	1, 4 & 13 Industrial use
E	7 & 9 and 4 & 13 Combined hazardous locations

f

Modification 1	
Add suffix codes in descending order whenever possible. (Optional. See page 13-41.)	

Product Selection



Style T — Type 1, 4 & 13
 with Pilot Light Option



Style T — Type 1, 4 & 13
 with Pilot Light, Range Locking Cap,
 and 5-Pin Mini-Receptacle

Style T Pressure Controls with Copper Alloy Bellows* — S.P.D.T. 2-Circuit Contact Block

Standard Pressure Controls shipped from the factory are set at the maximum operating range and minimum differential.

Pressure Specifications				Enclosure Type	
Adjustable Operating Range [psi]	Adjustable Differential [psi] (Approximate Mid-Range Values)	Maximum psi		Type 1, 4 & 13	Type 7 & 9 and 4 & 13 ‡
		Line Pressure	Occasional Surge Pressure*	Cat. No.	Cat. No.
30 in. Hg vacuum...35	2...7	80	90	836T-T251J	836T-T251E
6...75	3...15	200	220	836T-T252J	836T-T252E
12...150	6...30	350	450	836T-T253J	836T-T253E
20...300	10...55	600	750	836T-T254J	836T-T254E
40...450	20...90	900	1200	836T-T255J	836T-T255E
60...650	30...125	1300	1600	836T-T256J	836T-T256E

Style T Pressure Controls with Copper Alloy Bellows* — D.P.D.T. 4-Circuit Contact Block

Standard Pressure Controls shipped from the factory are set at the maximum operating range and minimum differential.

Pressure Specifications				Enclosure Type	
Adjustable Operating Range [psi]	Adjustable Differential [psi] (Approximate Mid-Range Values)	Maximum psi		Type 1, 4 & 13	Type 7 & 9 and 4 & 13 ‡
		Line Pressure	Occasional Surge Pressure*	Cat. No.	Cat. No.
30 in. Hg vacuum...35	2.2...7	80	90	836T-T251JX40	836T-T251EX40
6...75	4.5...15	200	220	836T-T252JX40	836T-T252EX40
12...150	9...30	350	450	836T-T253JX40	836T-T253EX40
20...300	15...55	600	750	836T-T254JX40	836T-T254EX40
40...450	30...90	900	1200	836T-T255JX40	836T-T255EX40
60...650	45...125	1300	1600	836T-T256JX40	836T-T256EX40

* Copper alloy bellows may be used on water or air, and other liquids or gases not corrosive to this alloy.

* Transients (pulses) can occur in a system prior to reaching a steady-state condition. Surge pressures within published values generated during startup or shutdown of a machine or system, not exceeding eight times in a 24-hour period, are negligible.

‡ The combined Type 7 & 9 and 4 & 13 hazardous gas and dust service enclosure is supplied with special gasket and O-ring seal to diminish/exclude moisture, fluids, and dust from entering the enclosure. Enclosure is rated for the following environments:
 CLASS I Groups C,D
 CLASS II Groups E,F,G
 CLASS III

Pressure Controls

Product Selection, Continued



Style T — Type 1, 4 & 13
with Pilot Light Option



Style T —
Type 7 & 9 and 4 & 13

Style T Pressure Controls with Type 316 Stainless Steel Bellows* — S.P.D.T. 2-Circuit Contact Block

Standard Pressure Controls shipped from the factory are set at the maximum operating range and minimum differential.

Pressure Specifications				Enclosure Type	
Adjustable Operating Range [psi]	Adjustable Differential [psi] (Approximate Mid-Range Values)	Maximum psi		Type 1, 4 & 13	Type 7 & 9 and 4 & 13 ‡
		Line Pressure	Occasional Surge Pressure*	Cat. No.	Cat. No.
30 in. Hg vacuum...35	2...7	65	65	836T-T260J	836T-T260E
8...100	4...20	200	200	836T-T261J	836T-T261E
24...250	12...50	500	500	836T-T262J	836T-T262E
40...375	20...90	600	600	836T-T263J	836T-T263E

Style T Pressure Controls with Type 316 Stainless Steel Bellows* — D.P.D.T. 4-Circuit Contact Block

Standard Pressure Controls shipped from the factory are set at the maximum operating range and minimum differential.

Pressure Specifications				Enclosure Type	
Adjustable Operating Range [psi]	Adjustable Differential [psi] (Approximate Mid-Range Values)	Maximum psi		Type 1, 4 & 13	Type 7 & 9 and 4 & 13 ‡
		Line Pressure	Occasional Surge Pressure*	Cat. No.	Cat. No.
30 in. Hg vacuum...35	2.2...7	65	65	836T-T260JX40	836T-T260EX40
8...100	6...20	200	200	836T-T261JX40	836T-T261EX40
24...250	18...50	500	500	836T-T262JX40	836T-T262EX40
40...375	30...90	600	600	836T-T263JX40	836T-T263EX40

* Type 316 stainless steel bellows are available for more corrosive liquids or gases.

‡ Transients (pulses) can occur in a system prior to reaching a steady-state condition. Surge pressures within published values generated during startup or shutdown of a machine or system, not exceeding eight times in a 24-hour period, are negligible.

‡ The combined Type 7 & 9 and 4 & 13 hazardous gas and dust service enclosure is supplied with special gasket and O-ring seal to diminish/exclude moisture, fluids, and dust from entering the enclosure. Enclosure is rated for the following environments:

- CLASS I Groups C,D
- CLASS II Groups E,F,G
- CLASS III





Style T — Type 1, 4 & 13



Style T —
 Type 1, 4 & 13 with Pilot Light,
 Mini-Receptacle, SAE Thread

Important Application Information

Piston-type controls are designed for use with oil and high water-based hydraulic fluids containing high-lubricity substances which will not attack alloy steel. Piston-type controls are available without seals to reduce piston friction. Reduced friction results in narrower switch differentials required for some applications.

All piston-type controls are equipped with a diaphragm assembly that conveys the motion of the piston to the mechanism, and prevents any fluid from entering the enclosure. Controls without seals are provided with a drain that should be connected to a line returning the piston by-pass fluid to a reservoir for reuse. The reservoir **must** be vented to the atmosphere. Manifold-type return lines that are fed by other equipment and/or contain a back-up check valve are not satisfactory. Extreme transient pulses can develop from hydraulic inertia in the line and rupture the diaphragm located on the secondary side of the piston, forcing fluid into the enclosure. For systems of this type, pressure controls with seals are recommended as return lines are not required if a slight amount of leakage, over time, can be tolerated. **Drains should never be plugged.** It is not recommended that a back pressure of more than the head pressure be applied to the diaphragm. This can occur if the reservoir is located above the machine. Variable back pressure may cause setting instability.

Listed differentials may vary due to piston and cylinder tolerance, and characteristics of the fluid and application. *Do not use piston-type controls on air, gases, or other liquids that will corrode stainless steel.*

Style T Pressure Controls Piston without Seal* — S.P.D.T. 2-Circuit Contact Block

(Hydraulic fluid return line to reservoir is recommended)

Standard Pressure Controls shipped from the factory are set at the maximum operating range and minimum differential.

Pressure Specifications				Enclosure Type	
Adjustable Operating Range [psi]	Adjustable Differential [psi] (Approximate Mid-Range Values)	Maximum psi		Type 1, 4 & 13	Type 7 & 9 and 4 & 13 ‡
		Line Pressure	Occasional Surge Pressure*	Cat. No.	Cat. No.
40...550	20...75	—	5000	836T-T300J	836T-T300E
70...1000	50...175	—	10000	836T-T301J	836T-T301E
200...3000	125...400	—	15000	836T-T302J	836T-T302E
350...5000	175...650	—	15000	836T-T303J	836T-T303E

Style T Pressure Controls Piston without Seal* — D.P.D.T. 4-Circuit Contact Block

(Hydraulic fluid return line to reservoir is recommended)

Standard Pressure Controls shipped from the factory are set at the maximum operating range and minimum differential.

Pressure Specifications				Enclosure Type	
Adjustable Operating Range [psi]	Adjustable Differential [psi] (Approximate Mid-Range Values)	Maximum psi		Type 1, 4 & 13	Type 7 & 9 and 4 & 13 ‡
		Line Pressure	Occasional Surge Pressure*	Cat. No.	Cat. No.
40...550	30...75	—	5000	836T-T300JX40	836T-T300EX40
70...1000	60...175	—	10000	836T-T301JX40	836T-T301EX40
200...3000	150...400	—	15000	836T-T302JX40	836T-T302EX40
350...5000	260...650	—	15000	836T-T303JX40	836T-T303EX40

* When phosphate ester base hydraulic fluid is present, a special diaphragm assembly is required. See Modifications, page 13-41.

* Transients (pulses) can occur in a system prior to reaching a steady-state condition. Surge pressures within published values generated during startup or shutdown of a machine or system, not exceeding eight times in a 24-hour period, are negligible.

‡ The combined Type 7 & 9 and 4 & 13 hazardous gas and dust service enclosure is supplied with special gasket and O-ring seal to diminish/exclude moisture, fluids, and dust from entering the enclosure. Enclosure is rated for the following environments:

- CLASS I Groups C,D
- CLASS II Groups E,F,G
- CLASS III



Style T — Type 1, 4 & 13



Style T — Type 1, 4 & 13 with Pilot Light, Mini-Receptacle, SAE Thread

Important Application Information

Piston-type controls are designed for use with oil and high water-based hydraulic fluids containing high-lubricity substances which will not attack alloy steel. Piston-type controls with seals are designed for applications where a fluid return line is not applicable.

All piston-type controls are equipped with a diaphragm assembly that conveys the motion of the piston to the mechanism, and prevents any fluid that may have by-passed the piston seal over time from entering the enclosure. Controls with seals generally do not require a return line as leakage is minimal. Seals are field replaceable (see page 13-43); however, pistons with seals are provided with a drain to specifically safeguard applications that require returning fluid back to the reservoir. The reservoir **must** be vented to the atmosphere. Manifold-type return lines that are fed by other equipment and/or contain a back-up check valve are not satisfactory. Extreme transient pulses can develop from hydraulic inertia in the line and rupture the diaphragm located on the secondary side of the piston, forcing fluid into the enclosure. **Drains should never be plugged.** It is not recommended that a back pressure greater than the head pressure be applied to the diaphragm. This can occur if the reservoir is located above the machine. Variable back pressure may cause setting instability.

Listed differentials may vary due to piston and cylinder tolerance, and characteristics of the fluid and application. *Do not use piston-type controls on air, gases, or other liquids that will corrode stainless steel.*

Style T Pressure Controls Piston with Seal* — S.P.D.T. 2-Circuit Contact Block

(Hydraulic fluid return line to reservoir is not required)

Standard Pressure Controls shipped from the factory are set at the maximum operating range and minimum differential.

Pressure Specifications				Enclosure Type	
Adjustable Operating Range [psi]	Adjustable Differential [psi] (Approximate Mid-Range Values)	Maximum psi		Type 1, 4 & 13	Type 7 & 9 and 4 & 13 ‡
		Line Pressure	Occasional Surge Pressure*	Cat. No.	Cat. No.
80...550	40...75	—	5000	836T-T350J	836T-T350E
140...1000	70...175	—	10000	836T-T351J	836T-T351E
400...3000	200...400	—	15000	836T-T352J	836T-T352E
700...5000	350...650	—	15000	836T-T353J	836T-T353E

Style T Piston with Seal* — D.P.D.T. 4-Circuit Contact Block

(Hydraulic fluid return line to reservoir is not required)

Standard Pressure Controls shipped from the factory are set at the maximum operating range and minimum differential.

Pressure Specifications				Enclosure Type	
Adjustable Operating Range [psi]	Adjustable Differential [psi] (Approximate Mid-Range Values)	Maximum psi		Type 1, 4 & 13	Type 7 & 9 and 4 & 13 ‡
		Line Pressure	Occasional Surge Pressure*	Cat. No.	Cat. No.
80...550	60...75	—	5000	836T-T350JX40	836T-T350EX40
140...1000	100...175	—	10000	836T-T351JX40	836T-T351EX40
400...3000	300...400	—	15000	836T-T352JX40	836T-T352EX40
700...5000	525...650	—	15000	836T-T353JX40	836T-T353EX40

Independent Trip and Reset Adjustment for Wide Differential Applications* — Piston with Seal, S.P.D.T. 2-Circuit Contact Block

(Hydraulic fluid return line to reservoir is not required)

Standard Pressure Controls shipped from the factory are set at the maximum operating range and minimum differential.

Pressure Specifications			Enclosure Type	
Adjustable High Trip Setting [psi]	Adjustable Low Reset Setting [psi]	Occasional Surge Pressure [psi]*	Type 1, 4 & 13	Type 7 & 9 and 4 & 13 ‡
			Cat. No.	Cat. No.
500...3000	0...250	15000	836T-T400J	836T-T400E

* When phosphate ester base hydraulic fluid is present, a special diaphragm and seal assembly is required. See Modifications, page 13-41.

‡ Transients (pulses) can occur in a system prior to reaching a steady-state condition. Surge pressures within published values generated during startup or shutdown of a machine or system, not exceeding eight times in a 24-hour period, are negligible.

‡ The combined Type 7 & 9 and 4 & 13 hazardous gas and dust service enclosure is supplied with special gasket and O-ring seal to diminish/exclude moisture, fluids, and dust from entering the enclosure. Enclosure is rated for the following environments:

- CLASS I Groups C,D
- CLASS II Groups E,FG
- CLASS III



Style D — Type 1, 4 & 13
 with Pilot Light Option



Style D — Type 1, 4 & 13

Style D Pressure Difference Controls with Copper Alloy Bellows* — S.P.D.T. 2-Circuit Contact Block†

Standard Pressure Difference Controls shipped from the factory are set at the maximum adjustable difference range and minimum differential.

Pressure Specifications					Enclosure Type 1, 4 & 13
Adjustable System Difference Range [psi]	Adjustable Differential [psi] (Approximate Mid-Range Values)	Line Pressure psi		Max. Occasional Surge Pressure [psi]*	Cat. No.
		Minimum	Maximum		
1...9	1...7	30 in. Hg Vac.	80	90	836T-D450J
2.5...20	2.5...15	30 in. Hg Vac.	175	200	836T-D451J
5...40	5...30	30 in. Hg Vac.	350	375	836T-D452J
10...70	10...50	0	600	650	836T-D453J

Style D Pressure Difference Controls with Copper Alloy Bellows* — D.P.D.T. 4-Circuit Contact Block†

Standard Pressure Difference Controls shipped from the factory are set at the maximum adjustable difference range and minimum differential.

Pressure Specifications					Enclosure Type 1, 4 & 13
Adjustable System Difference Range [psi]	Adjustable Differential [psi] (Approximate Mid-Range Values)	Line Pressure psi		Max. Occasional Surge Pressure [psi]*	Cat. No.
		Minimum	Maximum		
1...9	1.5...7	30 in. Hg Vac.	80	90	836T-D450JX40
2.5...20	3.75...15	30 in. Hg Vac.	175	200	836T-D451JX40
5...40	7.5...30	30 in. Hg Vac.	350	375	836T-D452JX40
10...70	15...50	0	600	650	836T-D453JX40

* Copper alloy bellows may be used on water or air, and other liquids or gases not corrosive to this alloy.

* Transients (pulses) can occur in a system prior to reaching a steady-state condition. Surge pressures within published values generated during startup or shutdown of a machine or system, not exceeding eight times in a 24-hour period, are negligible.

† Finger-safe shield supplied standard.

Pressure Controls

Product Selection, Continued



Style D — Type 1, 4 & 13
with Pilot Light Option



Style D — Type 1, 4 & 13

Style D Pressure Difference Controls with Type 316 Stainless Steel Bellows* — S.P.D.T. 2-Circuit Contact Block‡

Standard Pressure Difference Controls shipped from the factory are set at the maximum adjustable difference range and minimum differential.

Pressure Specifications					Enclosure Type 1, 4 & 13
Adjustable System Difference Range [psi]	Adjustable Differential [psi] (Approximate Mid-Range Values)	Line Pressure [psi]		Max. Occasional Surge Pressure [psi]*	Cat. No.
		Minimum	Maximum		
1...9	1...7	30 in. Hg Vac.	65	65	836T-D460J
5...25	4...15	0	175	200	836T-D462J
12...70	12...50	0	500	500	836T-D463J

Style D Pressure Difference Controls with Type 316 Stainless Steel Bellows* — D.P.D.T. 4-Circuit Contact Block‡

Standard Pressure Difference Controls shipped from the factory are set at the maximum adjustable difference range and minimum differential.

Pressure Specifications					Enclosure Type 1, 4 & 13
Adjustable System Difference Range [psi]	Adjustable Differential [psi] (Approximate Mid-Range Values)	Line Pressure [psi]		Max. Occasional Surge Pressure [psi]*	Cat. No.
		Minimum	Maximum		
1...9	1.5...7	30 in. Hg Vac.	65	65	836T-D460JX40
5...25	6...15	0	175	200	836T-D462JX40
12...70	18...50	0	500	500	836T-D463JX40

* Type 316 stainless steel bellows are available for more corrosive liquids or gases.

* Transients (pulses) can occur in a system prior to reaching a steady-state condition. Surge pressures within published values generated during startup or shutdown of a machine or system, not exceeding eight times in a 24-hour period, are negligible.

‡ Finger-safe shield supplied as standard.

Ordering Modifications

Modifications are ordered by adding the appropriate modification suffix code to the catalog number of the basic device. Add suffix codes to the catalog number in descending order.

Item	Description	Suffix Code
Oxygen/nitrous oxide service	Bellows and fittings specially prepared for oxygen and nitrous oxide service. Devices tested with pure oxygen, bellows plugged for protection from contamination and a tag warning against contamination is applied.	X2
External adjustment sealed	The 836T external adjustment is sealed, requiring cover removal to adjust differential (includes contact block shield)	X3
Tamper resistant setting	Range and differential adjustments are factory sealed. Price includes factory setting charge.*	X4
SAE 7/16-20 UNF thread O-ring boss seal (piston type pressure control)	Female SAE straight thread O-ring seal designed to prevent leaks and minimize loss of hydraulic fluids.	X6
SAE 9/16-18 UNF thread O-ring boss seal (piston type pressure control)		X7
Neon pilot light 120V AC	A high-intensity neon pilot light for 120V AC, 60 Hz applications is available and can be wired for ON or OFF operation. The current rating is 1.0 mA.*	X9
Red LED pilot light 24V DC	A high-intensity LED 24V DC pilot light is available to meet the requirements of the automotive, machine tool builders, and other industries. The current rating is 22 mA and can be wired for ON or OFF operation.*	X15
Green LED pilot light 24V DC		X18
Special diaphragm assembly (piston type pressure control)	Diaphragm is made of Viton® and Nomex® fabric. Required when phosphate ester base and other adverse hydraulic fluids are present. Use on Catalog Numbers 836T-T300J through 836T-T303J series controls.	X25
Special diaphragm and O-ring assembly (piston type pressure control)	Diaphragm is made of Viton® and Nomex® fabric, O-ring is made of Viton®. Required when phosphate esterbase and other adverse hydraulic fluids are present. Use on Catalog Numbers 836T-T350J , -T351J , -T352J , -T353J and -T400J series controls.	X26
Viton® enclosure gaskets	Special enclosure gaskets made of Viton® are available for applications where the standard gasket materials are not fluid compatible. Viton® is generally specified by the user for use with existing and newly developed coolants and hydraulic fluids to maintain enclosure integrity. These include cover, backplate, cover, and bellows or piston gaskets. Note: Viton® enclosure gaskets are often used with special diaphragm assemblies (X25 or X26). See description above.	X29
5-Pin mini-type receptacle without pilot light*	Select the desired pin wiring configuration from the diagrams on pages 13-45...13-47. Rated at 8 A, 600V.	See pages 13-45...13-47.
5-Pin mini-type receptacle with prewired pilot light*	Select the desired pin wiring, pilot light wiring, and voltage from the diagrams on pages 13-45...13-47. Includes receptacle and pilot light. Rated at 8 A, 600V.	See pages 13-45...13-47.
5-Pin micro-connect receptacle without pilot light*	Select the desired pin wiring configuration from the diagrams on pages 13-45...13-47. Add number "1" to the suffix number immediately following the letter "X." Example: "X19" becomes "X119." Rated at 3 A, 300V. Pin/Wiring Code: 1 – Red with white tracer, 2 – Red, 3 – Green (Gnd), 4 – Red with yellow tracer, 5 – Red with Black Tracer	See pages 13-45...13-47.
5-Pin micro-connect receptacle with prewired pilot light*	Select the desired pin wiring configuration and pilot light (X9 or X15, see above for specifications) from the diagrams on pages 13-45...13-47. Add number "1" to the Suffix Number immediately following the letter "X." Example: "X12X9" becomes "X121X9." Rated at 3 A, 300V. Pin/Wiring Code: 1 – Red with white tracer, 2 – Red, 3 – Green (Gnd), 4 – Red with yellow tracer, 5 – Red with black tracer	See pages 13-45...13-47.
Additional optional receptacles and wiring*	For assistance, please consult your local Rockwell Automation sales office or Allen-Bradley distributor.	

* See paragraph entitled "Factory-Set Pressure Controls" on page 13-44.

* Not available on the Type 7 & 9 and 4 & 13 combined enclosed devices.

Ordering Accessories

Accessories are ordered as separate catalog numbers. Select the required accessories from the accessories table below.

Item	Description	Type	Cat. No.
External fixed pulsation snubbers	Controls are supplied as standard with an internal pulsation snubber. However, a control properly selected and used within the adjustable range values, yet having a short bellows life, is a good indication of the presence of extreme surge pressures. External fixed pulsation snubbers are available to provide additional dampening when extreme pulsations or surges are present. Recommended if more than eight line surges occur in a 24-hour time period.	Snubber for bellows control 1/4-18 N.P.T. thread	836-N7
		Snubber for piston control 3/8-18 N.P.T. thread	836T-N8
Selectable element pulsation snubbers	Controls are supplied as standard with an internal pulsation snubber. However, a control properly selected and used within the adjustable range values, yet having a short bellows life, is a good indication of the presence of extreme surge pressures. Selectable element pulsation snubbers are supplied with five different elements to provide a selectable balance between maximizing pressure control life and minimizing control response time. Pulsation snubbers are supplied with the mid-range element already mounted and four other color-coded porosity elements included in the package. See "Selectable Pulsation Snubber Porosity Elements" table on this page for porosity specifications.	Snubber for bellows control 1/4-18 N.P.T. thread	836-N40
		Snubber for piston control 3/8-18 N.P.T. thread	836T-N41
	Female SAE straight thread O-ring seal designed to prevent leaks and minimize loss of hydraulic fluids. Use on applications with a pressure range of 550...5000 psi.	SAE 7/16-20 UNF-2B thread O-ring boss seal for piston controls	836T-N49
		SAE 9/16-18 UNF-2B thread O-ring boss seal for piston controls	836T-N50
Selectable pulsation snubber porosity elements	Package consists of five porosity elements and complete instructions. Elements are color-coded for easy identification. Elements are available in five different porosities for a wide range of applications. See selectable pulsation snubber porosity elements table.		See Table on this page
Locking cap	Deters unauthorized tampering of range setting. Once installed, the locking cap can be removed with a screwdriver to re-adjust the control.	—	836T-N13
Isolation trap with two 1/4 in. male pipe fittings	An isolation trap is available for high-temperature media applications from 150...600 °F or corrosive applications compatible with Type 316 stainless steel tubing and fittings. The isolation coil is inserted between the bellows of the pressure control and the elevated temperature line of the system. The isolation trap will fill with condensed water or can be filled with water or suitable fluid when installed. A silicone buffer fluid is available in a convenient dispenser. Copper alloy lower and higher pressure range bellows can be applied to many applications using the isolation trap. The silicone buffer fluid is used to isolate many corrosive substances from coming in contact with the bellows. The isolation trap is rated at 3000 psi working pressure. Not available for piston-type controls. See photo on this page.		836-N25
Isolation trap with one 1/4 in. male and one 1/4 in. female pipe fittings			836-N26
2 oz. of buffer fluid to fill bellows and tubing			836-N27
Metric electrical entry conduit adapters	BS 20 mm thread adapter		836T-N36
	Pg 13.5 thread adapter		836T-N37

Selectable Pulsation Snubber Porosity Elements

Recommended Type of Service	Color Code	Porosity	Cat. No.
Viscous fluids (over 500 SSU)*	None	Coarser	836-N43
Medium type oils (225...500 SSU)*	Black		836-N44
Water and light oils (30... 225 SSU)*	Brown		836-N45
Low viscosity fluids (under 30 SSU)*	Green		836-N46
Air and other gases	Red	Finer	836-N47
One of each of the above	—	Assorted	836-N48

* Saybolt Seconds Universal (SSU) — units of viscosity measurement.

Note: Color code is located on end of element.



Isolation Trap and Silicone Buffer Fluid

Fixed Pulsation Snubbers



Male/Female Pipe Threads

Selectable Element Pulsation Snubbers



Male/Female Pipe Threads

Pulsation Snubbers

Conversion Kits

Ordering Conversion Kits

Conversion Kits are ordered by adding the appropriate suffix code to the catalog number of the basic device. Select the required conversion kits from the table below.

Conversion Kits

Item	Description	Suffix Code
Neon pilot light conversion kit	Converts standard control to control with 120V AC neon pilot light. Not available on Type 7 & 9 devices. Kit includes pilot light and cover assembly.	N9
Red LED pilot light conversion kit	Converts standard control to control with 24V DC LED pilot light; has a 22 mA current rating. Not available on Type 7 & 9 devices. Kit includes pilot light and cover assembly.	N15
Green LED pilot light conversion kit	Converts standard control to control with 24V DC LED pilot light; has a 22 mA current rating. Not available on Type 7 & 9 devices. Kit includes pilot light and cover assembly.	N18

Example:

To convert a **Cat. No. 836T-T301J** to a **Cat. No. 836T-T301JX15**, order **Cat. No. 836T-T301JN15**.

Renewal Parts

Ordering Renewal Parts

Renewal Parts are ordered as separate catalog numbers. Select the required renewal parts from the table below.

Renewal Parts

Item	Description	Cat. No.
2-Circuit contact block renewal kit	Allows renewal of worn contacts for Bulletin 836T controls.	836T-N1
4-Circuit contact block renewal kit	Allows renewal of worn contacts for Bulletin 836T controls.	836T-N2
Renewal seals for piston-type controls	For use on Cat. No. 836T-T350J.	836T-N20
	For use on Cat. No. 836T-T351J.	836T-N21
	For use on Cat. No. 836T-T352J and 836T-T400J.	836T-N22
	For use on Cat. No. 836T-T353J.	836T-N23

Factory-Set Pressure Controls

Ordering factory-set pressure controls

- When a specific factory setting is requested, the specific terminal connections must be specified — e.g., N.O. or N.C. It must also be specified whether the contact operation is occurring on either increasing or decreasing pressure. For example:

Normally Closed (N.C.) contacts to open at* psi increasing pressure and close at* psi decreasing pressure.

—OR—

Normally Open (N.O.) contacts to close at* psi increasing pressure and open at* psi decreasing pressure.

- If minimum differential is not critical and the inherent minimum differential satisfies the application, specify the factory setting as follows:

Normally Closed (N.C.) contacts to open at* psi increasing pressure minimum differential.

—OR—

Normally Open (N.O.) contacts to close at* psi increasing pressure minimum differential.

- * Specify psi (pounds per square inch) or, in. Hg vac (inches of mercury vacuum).
- * Per ANSI B40.1 Grade 2A (0.5% accuracy full scale), Grade 3A (0.25% accuracy full scale).

If not specified, setting tolerances will be as shown in the table below.

Pressure Range	Tolerance
30 in. Hg Vac...0	+/- 1 in. Hg vac.
> 0...100 psi	+/- 1 psi
> 100...300 psi	+/- 2 psi
> 300...500 psi	+/- 5 psi
> 500...1000 psi	+/- 10 psi
> 1000...5000 psi	+/- 50 psi

Standards Compliance

- UL508
- UL698, 1604 (Haz. Loc.)
- CSA 22,2 No. 14
- NEMA ICS-2

Certifications



File and Guide Numbers

	UL		CSA	
	File Number	Guide Number	File Number	Class
Bulletin 836T	E14842	NKPZ	LR1234	3211-03
	E53048 (Haz. Loc.)	NOWT	LR11924 (Haz. Loc.)	3218-05
Hazardous Location enclosure devices are not CE compliant. All other enclosed devices are CE compliant.				

Quality analog test gauges§ are used when applying requested factory settings to these rugged industrial grade pressure controls. (Gauges are calibrated and accuracy is traceable to the The National Institute of Standards and Technology.)

The actual requested setting is applied to the control by reading the set point directly from the test gauge being used. However, traceable gauge tolerance variance between source and user, and possible severe shock during shipping and installation, may contribute to the factory settings deviating slightly from the specified values. Slight recalibration can easily be accomplished upon final installation to meet specific requirements for the more demanding applications.

When installed, the controls will perform with a repeat accuracy as established in the paragraph entitled "Repeat Accuracy" (see page 13-54). Special service is available to factory-set controls on digital laboratory instruments, up to 600 psi, when required for more critical applications. An additional charge may be added for this service contingent upon setting tolerance and quantity. Please contact your local Rockwell Automation sales office or Allen-Bradley distributor.

Bulletin 836T 5-Pin Mini-Type Receptacle Option Wiring Reference

(J1 Wiring)

(See applicable codes and laws)

Without Pilot Light

Suffix X19

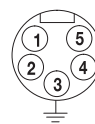
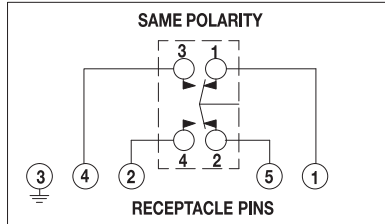

PIN/WIRE CODE

- 1= White
- 2= Red
- 3= Green
- 4= Orange
- 5= Black

PRESSURE: CIRCUIT 1-2 (PINS 1 & 5)
 OPENS ON RISING PRESSURE

VACUUM: CIRCUIT 3-4 (PINS 4 & 2)
 OPENS ON INCREASING VACUUM
 (TOWARD 30 in. HG)

With Pilot Light*

Suffix X21X9

WITH NEON GLOW PILOT LIGHT 120V AC ONLY
 PILOT LIGHT WIRED ACROSS CIRCUIT
 1-2 (PINS 1 & 5)

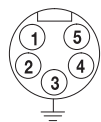
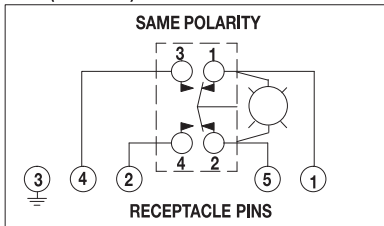

PIN/WIRE CODE

- 1= White
- 2= Red
- 3= Green
- 4= Orange
- 5= Black

PRESSURE: CIRCUIT 1-2 (PINS 1 & 5)
 OPENS ON RISING PRESSURE

VACUUM: CIRCUIT 3-4 (PINS 4 & 2)
 OPENS ON INCREASING VACUUM
 (TOWARD 30 in. HG)

Suffix X22X9 ‡

WITH NEON GLOW PILOT LIGHT 120V AC ONLY
 PILOT LIGHT WIRED ACROSS CIRCUIT
 3-4 (PINS 4 & 2)

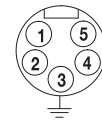
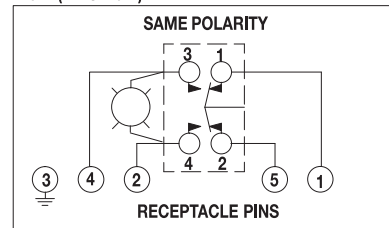

PIN/WIRE CODE

- 1= White
- 2= Red
- 3= Green
- 4= Orange
- 5= Black

PRESSURE: CIRCUIT 1-2 (PINS 1 & 5)
 OPENS ON RISING PRESSURE

VACUUM: CIRCUIT 3-4 (PINS 4 & 2)
 OPENS ON INCREASING VACUUM
 (TOWARD 30 in. HG)

Suffix X21X15

WITH LED PILOT LIGHT 24V DC ONLY
 PILOT LIGHT WIRED ACROSS CIRCUIT
 1-2 (PINS 1 & 5)

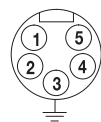
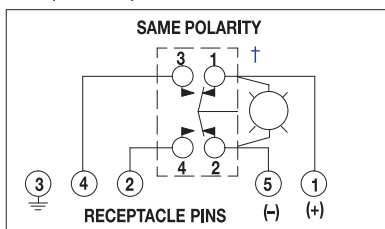

PIN/WIRE CODE

- 1= White
- 2= Red
- 3= Green
- 4= Orange
- 5= Black

PRESSURE: CIRCUIT 1-2 (PINS 1 & 5)
 OPENS ON RISING PRESSURE

VACUUM: CIRCUIT 3-4 (PINS 4 & 2)
 OPENS ON INCREASING VACUUM
 (TOWARD 30 in. HG)

Suffix X22X15 ‡

WITH LED PILOT LIGHT 24V DC ONLY
 PILOT LIGHT WIRED ACROSS CIRCUIT
 3-4 (PINS 4 & 2)

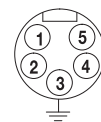
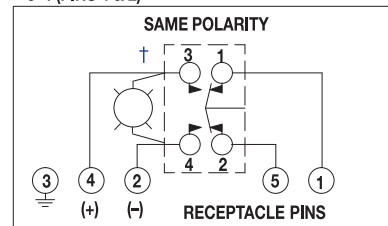

PIN/WIRE CODE

- 1= White
- 2= Red
- 3= Green
- 4= Orange
- 5= Black

PRESSURE: CIRCUIT 1-2 (PINS 1 & 5)
 OPENS ON RISING PRESSURE

VACUUM: CIRCUIT 3-4 (PINS 4 & 2)
 OPENS ON INCREASING VACUUM
 (TOWARD 30 in. HG)

* The pilot lights shown in these diagrams are wired across the terminals and in series with the load. Pilot light is OFF when the load is energized, ON when the load is de-energized. For simultaneous energization of the load and pilot light, or other optional wiring configurations, consult your local Rockwell Automation sales office or Allen-Bradley distributor.

‡ Note pilot light polarity.

‡ X22 not available with 4-circuit pressure controls.

Bulletin 836T 5-Pin Mini-Type Receptacle Option Wiring Reference

(J9 Wiring)

(See applicable codes and laws)

Without Pilot Light

Suffix X20

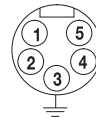
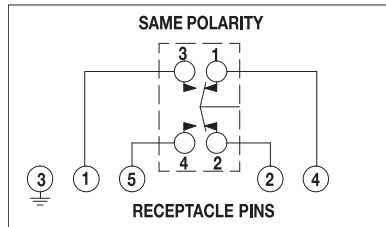

PIN/WIRE CODE

- 1= White
- 2= Red
- 3= Green
- 4= Orange
- 5= Black

PRESSURE: CIRCUIT 1-2 (PINS 4 & 2)
 OPENS ON RISING PRESSURE
VACUUM: CIRCUIT 3-4 (PINS 1 & 5)
 OPENS ON INCREASING VACUUM
 (TOWARD 30 in. HG)

With Pilot Light*

Suffix X23X9

WITH NEON GLOW LIGHT 120V AC ONLY
 PILOT LIGHT WIRED ACROSS CIRCUIT
 1-2 (PINS 4 & 2)

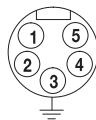
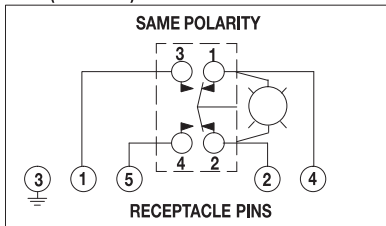

PIN/WIRE CODE

- 1= White
- 2= Red
- 3= Green
- 4= Orange
- 5= Black

PRESSURE: CIRCUIT 1-2 (PINS 4 & 2)
 OPENS ON RISING PRESSURE
VACUUM: CIRCUIT 3-4 (PINS 1 & 5)
 OPENS ON INCREASING VACUUM
 (TOWARD 30 in. HG)

Suffix X24X9

WITH NEON GLOW LIGHT 120V AC ONLY
 PILOT LIGHT WIRED ACROSS CIRCUIT
 3-4 (PINS 1 & 5)

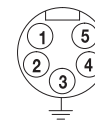
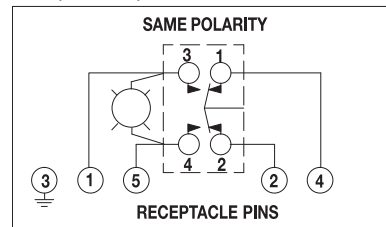

PIN/WIRE CODE

- 1= White
- 2= Red
- 3= Green
- 4= Orange
- 5= Black

PRESSURE: CIRCUIT 1-2 (PINS 4 & 2)
 OPENS ON RISING PRESSURE
VACUUM: CIRCUIT 3-4 (PINS 1 & 5)
 OPENS ON INCREASING VACUUM
 (TOWARD 30 in. HG)

Suffix X23X15

WITH LED PILOT LIGHT 24V DC ONLY
 PILOT LIGHT WIRED ACROSS CIRCUIT
 1-2 (PINS 4 & 2)

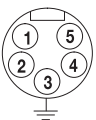
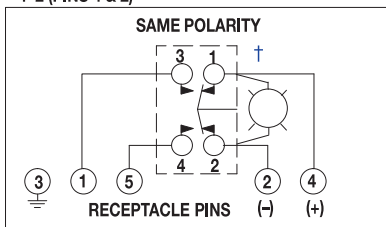

PIN/WIRE CODE

- 1= White
- 2= Red
- 3= Green
- 4= Orange
- 5= Black

PRESSURE: CIRCUIT 1-2 (PINS 4 & 2)
 OPENS ON RISING PRESSURE
VACUUM: CIRCUIT 3-4 (PINS 1 & 5)
 OPENS ON INCREASING VACUUM
 (TOWARD 30 in. HG)

Suffix X24X15

WITH LED PILOT LIGHT 24V DC ONLY
 PILOT LIGHT WIRED ACROSS CIRCUIT
 3-4 (PINS 1 & 5)

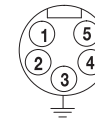
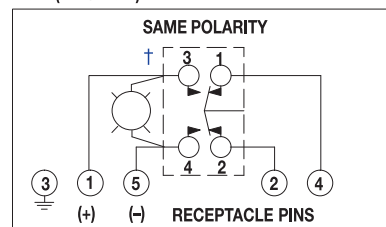

PIN/WIRE CODE

- 1= White
- 2= Red
- 3= Green
- 4= Orange
- 5= Black

PRESSURE: CIRCUIT 1-2 (PINS 4 & 2)
 OPENS ON RISING PRESSURE
VACUUM: CIRCUIT 3-4 (PINS 1 & 5)
 OPENS ON INCREASING VACUUM
 (TOWARD 30 in. HG)

* The pilot lights shown in these diagrams are wired across the terminals and in series with the load. Pilot light is OFF when the load is energized, ON when the load is de-energized. For simultaneous energization of the load and pilot light, or other optional wiring configurations, consult your local Rockwell Automation sales office or Allen-Bradley distributor.

* **Note pilot light polarity.**

Bulletin 836T 5-Pin Mini-Type Receptacle Option Wiring Reference

(See applicable codes and laws)

With Pilot Light

Suffix X81X9

WITH NEON GLOW PILOT LIGHT 120V AC ONLY
 RATED 600V 8 AMPS

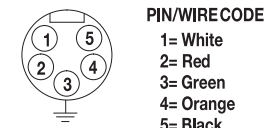
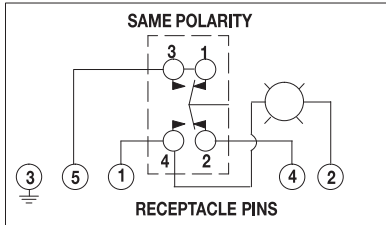

PRESSURE: CIRCUIT 1-2 (PINS 5 & 4)
 OPENS ON RISING PRESSURE
VACUUM: CIRCUIT 3-4 (PINS 5 & 1)
 OPENS ON INCREASING VACUUM
 (TOWARD 30 in. HG)

Suffix X81X15

WITH LED PILOT LIGHT 24V DC ONLY
 RATED 600V 8 AMPS

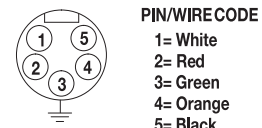
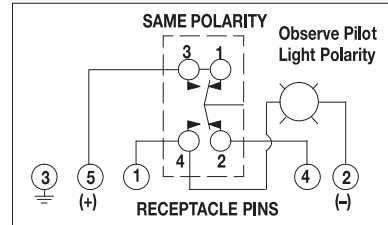

PRESSURE: CIRCUIT 1-2 (PINS 5 & 4)
 OPENS ON RISING PRESSURE
VACUUM: CIRCUIT 3-4 (PINS 5 & 1)
 OPENS ON INCREASING VACUUM
 (TOWARD 30 in. HG)

Note: Bulletin 836T Suffix “X81” Wiring — load and pilot light simultaneously energize when contacts displace (contact terminals 3 and 4 close) at a predetermined pressure setting.

Approximate Dimensions and Shipping Weights

Dimensions in inches (millimeters). Dimensions are not intended to be used for manufacturing purposes.

**Type 4 & 13
 (Bellows)**

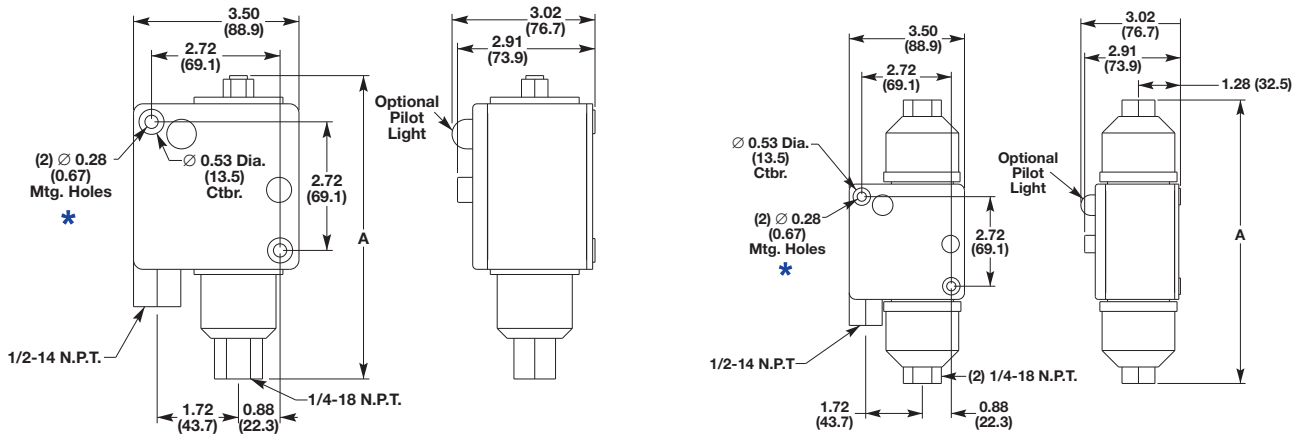

Approximate Shipping Weight 3-1/2 lbs. (1.6 kg)

Approximate Shipping Weight 4 lbs. (1.8 kg)

Cat. No.	A Dimensions	Cat. No.	A Dimensions	Cat. No.	A Dimensions	Cat. No.	A Dimensions
836T-T251J	6.65 (169)	836T-T254J	6.95 (176)	836T-D450J	8.60 (218)	836T-D460J	8.60 (218)
836T-T260J		836T-T255J		836T-D451J		836T-T252J	
—	—	836T-T256J	7.09 (180)	836T-D452J	8.14 (207)	836T-T253J	8.5 (216)
836T-T252J	6.41 (163)	836T-T262J	7.33 (186)	836T-D453J		9.5 (241)	836T-D463J
836T-T253J		836T-T263J	7.25 (184)				
836T-T261J							

**Type 4 & 13
 (Piston)**

(Does not include Dual Bellows Devices)

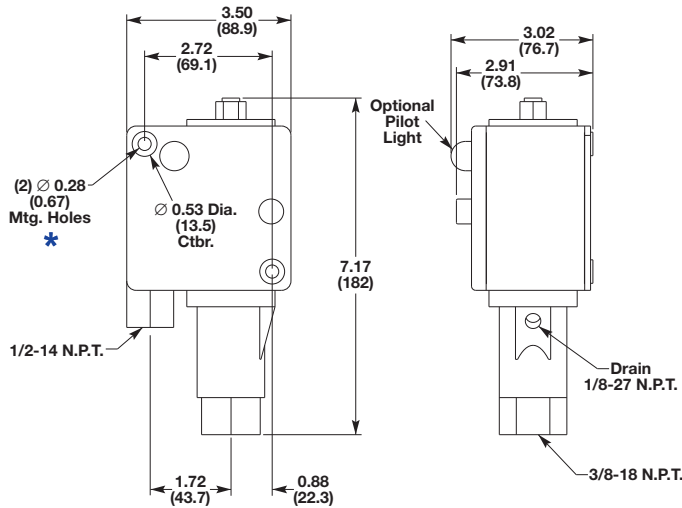

Approximate Shipping Weight 4.5 lbs. (2.0 kg)

**Type 4 & 13 and 7 & 9
 Bellows and Piston Type**

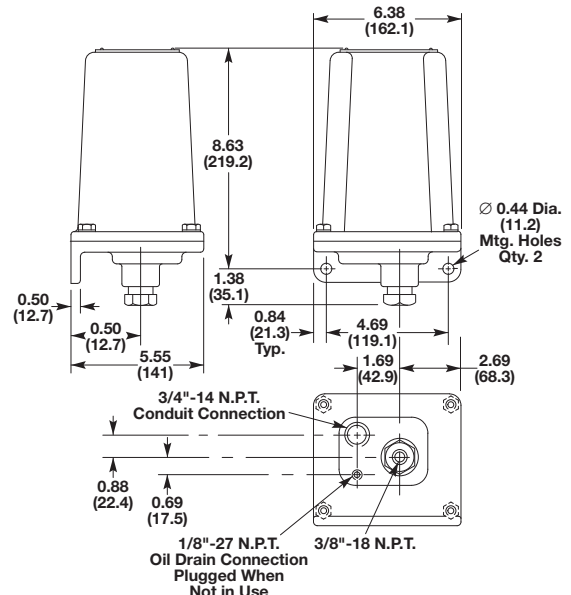

Approximate Shipping Weight 10 lbs. (4.5 kg)

* (2) mounting screws are required: 3/16 x 20 x 2 in. Counterbore depth is 1-1/8 in. Overall depth of mtg hole (front to back) is 2-1/4 in.

Cat. No.	
836T-T300J	836T-T350J
	836T-T351J
836T-T301J	836T-T352J
836T-T302J	836T-T353J
836T-T303J	836T-T400J



Bulletin 837 Temperature Controls

- Operating ranges from -60...+570 °F
- Adjustable range and differential
- Remote bulb sensing or direct immersion types
- Stainless steel bulb, capillary, and armor available
- Variety of contact blocks available
- Open Type, Type 1, Type 4 & 13, Type 4X, and Type 7 & 9 and 4 & 13 combination enclosures

Table of Contents

Product Overview..... this page
 Technical Data 13-51
 Product Selection 13-55
 Modifications 13-58
 Accessories..... 13-60
 Approximate
 Dimensions..... 13-62

Standards Compliance and Certifications

(For file and guide numbers see page 13-61)

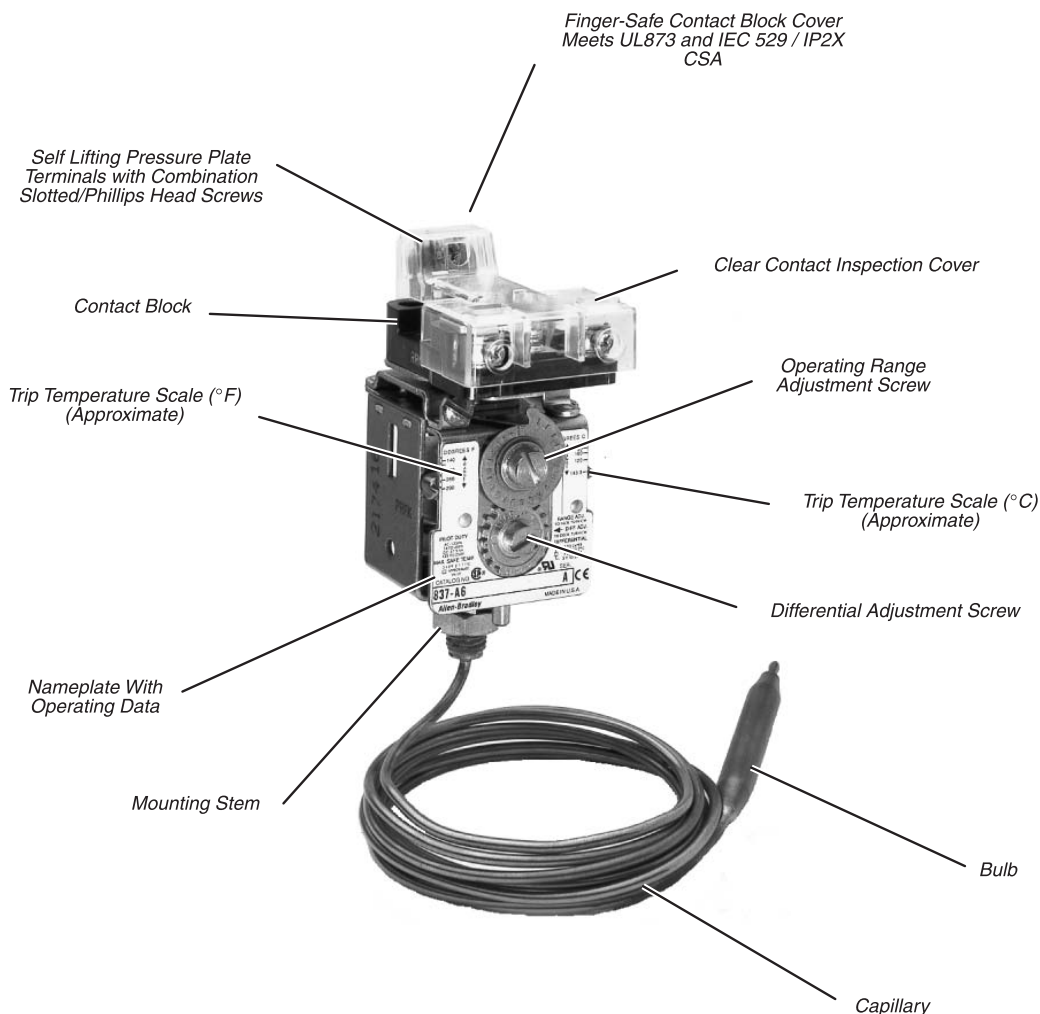

Bulletin 837 Bulb and Capillary Type without Enclosure

Description

Bulletin 837 Temperature Controls are heavy-duty control circuit devices used in industrial applications where the temperature must be maintained within preset limits. These devices use a vapor pressure technology to sense changes in temperature. The pressure change is transmitted to the bellows through a bulb and capillary tube. Pressure in the system changes in proportion to the temperature of the bulb. Vapor pressure technology provides excellent repeat accuracy and exceptionally long life. Bulletin 837 Temperature Controls are designed for long life and heavy duty operation. Standard controls have precision snap-action silver contacts, and are offered in three different styles. All styles make use of bulbs and capillaries filled with a temperature-responsive

liquid for detecting temperature changes. The controls are available in a wide variety of enclosures. There are many options and modifications available to meet most application requirements.

Applications

- Ovens
- Refrigeration units
- Machine coolants
- Bearing temperature
- Die temperature
- Water freeze protection

Style A — Remote Bulb and Capillary**Copper alloy bulb and capillary**

- Adjustable operating range from $-60\dots+360$ °F
- Bulb may be located up to 6 feet from the control (standard)
- Adjustable range and differential
- Enclosure types: Open Type, Type 1, 4 & 13, and combined 7 & 9 and 4 & 13
- Maximum temperature up to 400 °F

Stainless steel bulb and capillary

- Adjustable operating range from 260...570 °F
- Bulb and capillary resist oxide due to high temperature
- Bulb may be located up to 6 feet from the control (standard)
- Adjustable range and differential
- Enclosure types: Open Type, Type 1, 4 & 13, 4X, and combined 7 & 9 and 4 & 13
- Maximum temperature up to 600 °F

Style H — Direct Horizontal Immersion**Brass bulb**

- Adjustable operating range from 25...290 °F
- Direct horizontal mount on equipment
- Enclosure types: Open Type, and Type 1
- Maximum temperature up to 340 °F
- Maximum pressure is 300 psi without thermostat well

Style V — Direct Vertical Immersion**Brass bulb**

- Adjustable operating range from 25...290 °F
- Direct vertical mount on equipment
- Enclosure types: Open Type, Type 1 and 4 & 13
- Maximum temperature up to 340 °F
- Maximum pressure is 300 psi without thermostat well

Technical Terms

Adjustable operating range — Total span within which the contacts can be adjusted to trip and reset.

Trip setting — Higher temperature setting when the contacts transfer from their normal state to a changed state.

Reset setting — Lower temperature setting when the contacts return to their normal state.

Adjustable differential — Difference between the trip and reset values.

Minimum differential — When the differential is set to the lowest temperature difference between trip and reset.

Maximum differential — When the differential is set to the highest temperature difference between trip and reset.

Maximum temperature — The maximum temperature that can be applied to the bulb. This includes temperature override that may occur in the system. **This rating must NOT be exceeded.**

Operating range adjustment screw — This screw is used to adjust the trip setting by varying the force of the main spring.

Differential adjustment screw — This screw is used to adjust reset setting by varying the force of the differential blade spring.

Contact configuration — There are many types of contact configurations available. Bulletin 837 Temperature Controls are offered in a wide variety of contact configurations for both automatic operation and manual reset. See page 13-58.

Mounting — There are two methods of mounting temperature controls: remote or direct immersion.

- Remote Method — A bulb and capillary system is used for mounting the control away from the machine or process.
- Direct Immersion — The control is mounted directly on the machine or process. Rockwell Automation offers both horizontal and vertical immersion types.

Conversion factor — Temperatures given in Fahrenheit can be converted to Celsius using this equation: $^{\circ}\text{C} = 0.56 (^{\circ}\text{F} - 32^{\circ})$
 Temperatures given in Celsius can be converted to Fahrenheit using this equation: $^{\circ}\text{F} = (1.8 \times ^{\circ}\text{C}) + 32^{\circ}$

Figure 1
 Graphics to illustrate technical terms

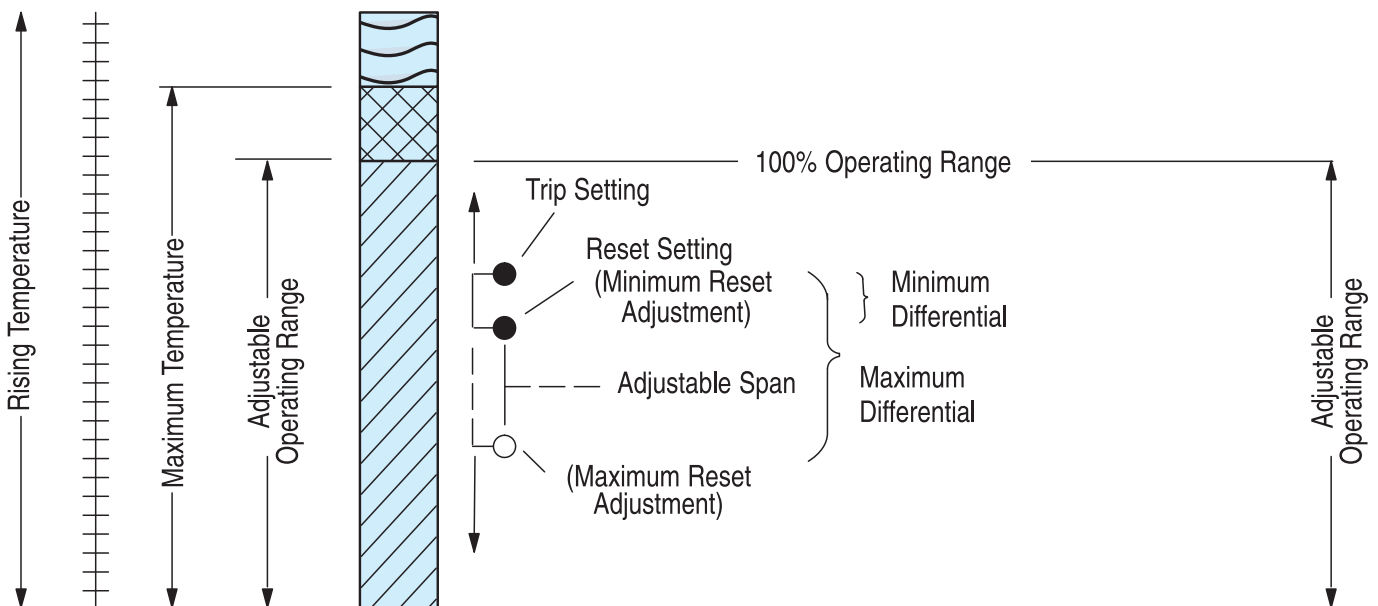

Theory of Operation

Bulletin 837 Temperature Controls are designed to open or close electrical circuits in response to changes in temperature. Figure 2 is a simplified drawing of a temperature control. The bellows, bulb, and capillary are filled with a temperature-responsive liquid. The vapor pressure of the liquid increases as the temperature of the bulb increases. System temperature is converted to pressure through the bulb and capillary, which are connected to the control at the mounting stem. Pressure applied to the actuator changes in proportion to the temperature of the bulb. As temperature rises, the bellows exerts force on the main spring. When the threshold force of the main spring is overcome, it transfers the motion to the contact block and actuates the contacts — this is referred to as the trip setting. As temperature decreases, the main spring will retract. When the threshold force on the differential blade spring is overcome, the contacts will return to their normal state — this is referred to as reset setting. Varying the force of the main spring (by turning the operating range adjustment screw) determines when the contacts will trip. Varying the force on the secondary differential blade spring (by turning the differential adjustment screw) determines when the contacts will reset. Setting trip and reset determines control operation.

Figure 2
Basic Mechanical Structure

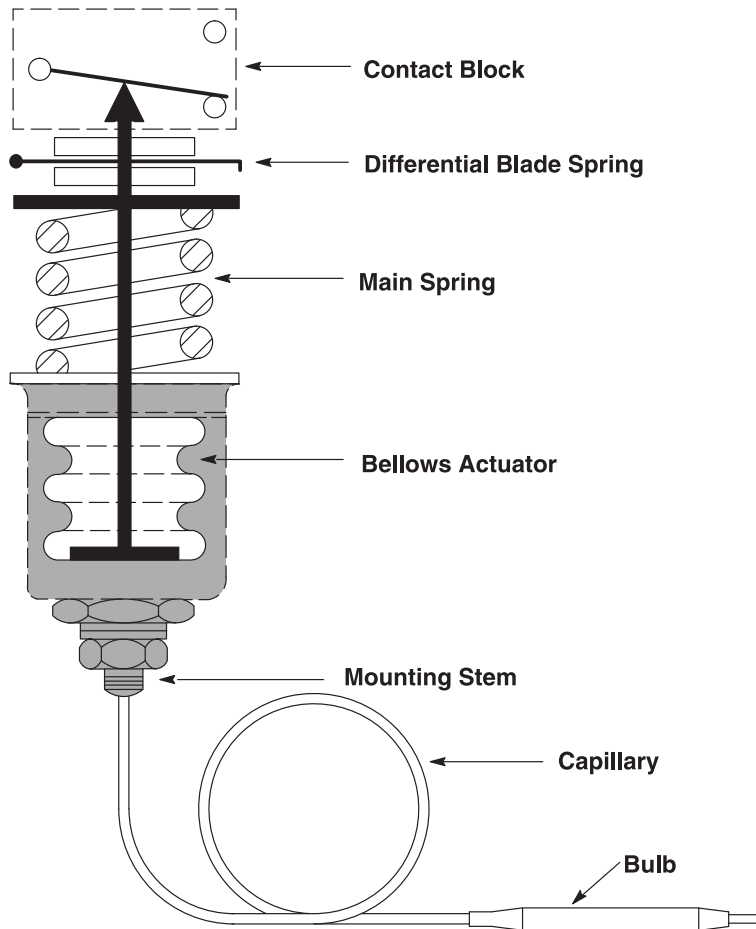

Applications for Control

Temperature controls can be used to either control or monitor a machine or process. Figure 3 shows a typical control application. Here, temperature is controlled within predetermined high and low values. Figure 4 shows a typical monitoring application. Here, temperature is monitored between a high and low value, signaling when a preset limit has been exceeded.

Figure 3
Typical Control Application

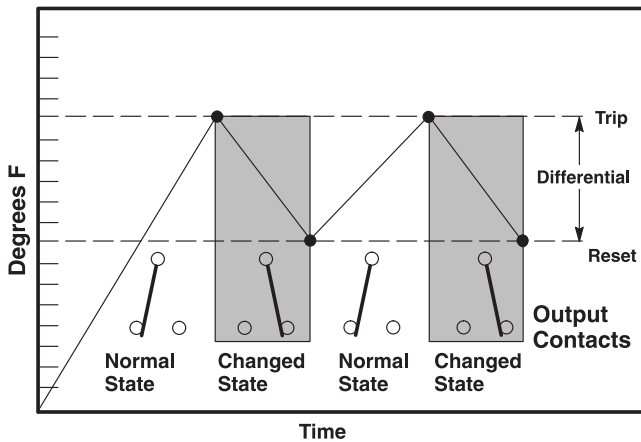
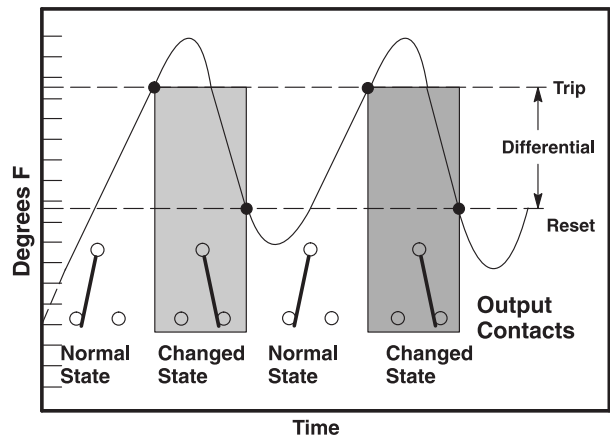

Figure 4
Typical Monitoring Application



Control Settings

Allen-Bradley Temperature Controls are designed for ease of setting to help minimize installation time. Standard controls shipped from the factory are set at the maximum operating range and minimum differential. By following this simple two step process, the control can be set to the specific requirements for each application. See Figure 5.

Step 1 — Adjust trip setting

The trip setting is achieved by turning the operating range adjustment screw. Turn the screw counterclockwise to lower the trip setting or clockwise to raise the trip setting. The approximate trip setting is shown on the indicating scale.

Step 2 — Adjust reset setting

The reset setting is achieved by turning the differential adjustment screw counterclockwise to increase the differential or clockwise to decrease the differential.

Figure 5
Trip and reset adjustment

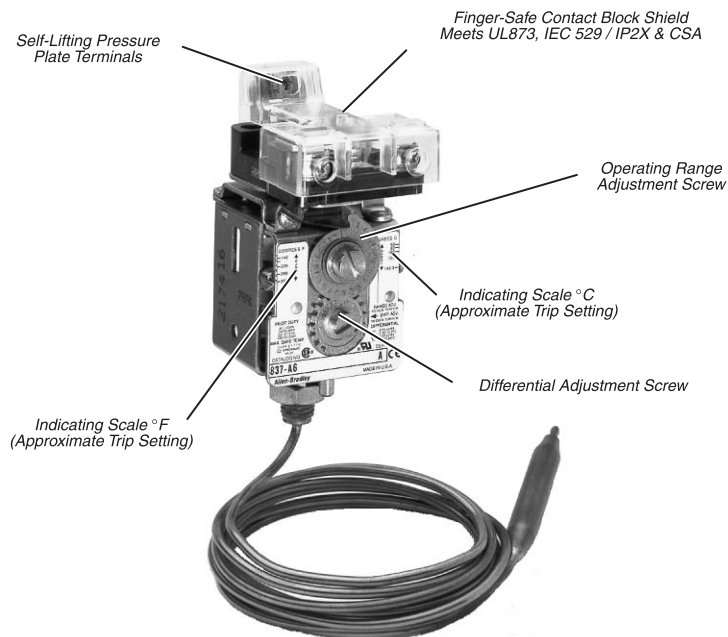

Temperature Controls

Technical Data, Continued

Thermostat Wells

Thermostat wells are basically sealed tubes on one end with threads on the other that allow mounting directly into a system. Thermostat wells protect the bulbs and allow installing or removing controls for calibration without discharging or draining an entire system. The bulb of a temperature control is inserted into the well which is secured with a locking nut for standard bulb and capillary devices. Bulbs for armored capillary devices are secured with a sleeve nut and set screw to prevent the armor from sliding back exposing the capillary. The bulbs of direct immersion devices are secured with a set screw which is also used to mount the control. Thermostat wells are rated for 1000 psi at 600 °F. Thermostat wells used when mounting direct horizontal immersion controls will allow mounting the control in a confined space. These devices otherwise require an 11 in. swing diameter to secure the bulb into the system. See page 13-60.

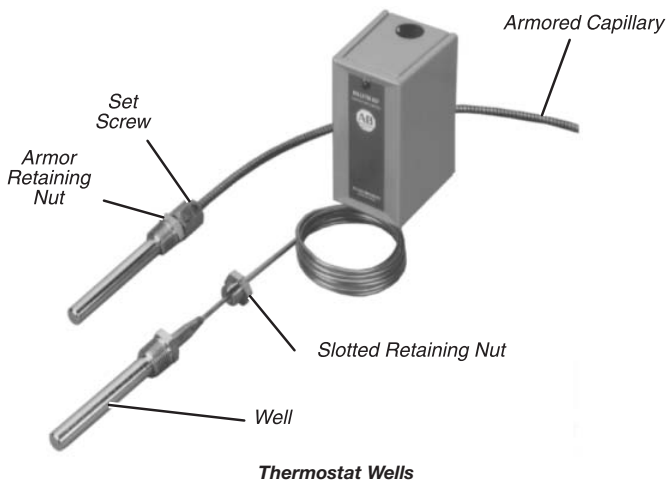

Packing Glands

Packing glands are used when the application requires the bulb to be located deeper into a process than would be possible with a thermostat well. The glands provide a seal at any desired length along a standard capillary device. The bulb must be supported to resist damage from flow or turbulence within the system. The capillary of armored capillary devices can only be sealed at the small exposed section of capillary located at the bulb. Packing glands are not intended to seal around the armor. They are designed to withstand sealing pressures up to 50 psi. The packing gland cannot be assembled into a thermostat well. See page 13-60.

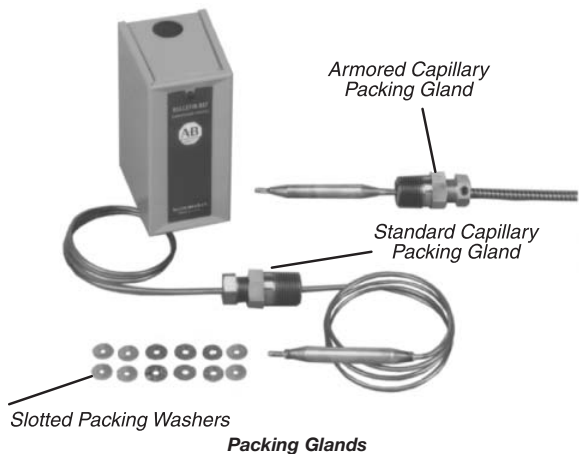

Bulb and Capillaries

Copper bulbs and capillaries are supplied for lower temperature ranges. Stainless steel is used for temperatures above 260 °F. Stainless steel is also available on lower ranges for more corrosive applications. The length of the standard capillary is 6 feet, but non-standard capillaries are available ranging from several inches up to 105 feet.

Armor

Bronze or stainless steel armor is available for added protection of the capillary. See Modifications on page 13-59 for ordering instructions.

Capillary Bending Radius

Copper and Stainless Steel —
0.5 in. (12.7 mm) minimum
with Bronze and Stainless Steel Armor —
2 in. (50.8 mm) minimum

Direct Immersion

Horizontal and vertical immersion devices are used when the controls are required to be mounted directly on the machine or in a process.

Standard Contact*

Contact Operation

Contact blocks are single-pole, double-throw and can be wired to open or close on increasing or decreasing temperature.

Non-Inductive Ratings

5 A, 240V
3 A, 600V

Control Circuit Ratings

AC — 125 VA, 24...600V
DC — 57.5 VA, 115...230V

Standard Contact Wiring Configuration

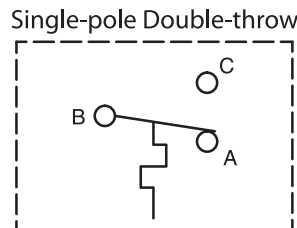

Repeat Accuracy

The vapor pressure technology used in Bulletin 837 controls to sense temperature provides an exceptionally long operating life. High quality chemicals and rigid control during manufacturing provide a typical repeat accuracy of ± 2 °F. Repeat accuracy is based on percent of maximum range, evaluated from test data and calculated using the formula per ICS 2-225 standards.

Special Controls

A large number of unlisted catalog modifications and complete devices are available for specific and OEM applications. Special controls and modification service is available to meet many applications unique to the OEM market.

Please consult your local Rockwell Automation sales office or Allen-Bradley distributor for assistance with specific modified controls and accessories.

Temperature Range

The temperature range for the mechanism at +32 °F (0 °C) or below is based on the absence of freezing moisture, water or other fluids that may solidify and impede the operation of the control.

Temperature ratings are as follows:

- Operating: -22... +150 °F
(-30...+66 °C)
- Storage: -22...+200 °F
(-30...+93 °C)

Factory-Set Temperature Controls

Rockwell Automation will factory set temperature controls to customer-specified values. Unspecified temperature controls shipped from the factory are set at the maximum operating range and minimum differential. See Factory Options, page 13-61.

Application Note

When the ambient temperature surrounding the mechanism of the temperature control approaches 30 °F (-1.1 °C) on either side of the setting, a cross-ambient type control should be used. This will protect against false temperature-sensing, as the bellows within the mechanism may otherwise respond to changes in temperature. Cat. Nos. **837-A3** and **837-A4** bulb and capillary Types, all **837-V** direct vertical immersion, and all **837-H** direct horizontal immersion devices are cross-ambient.

When the bulb of cross-ambient bulb and capillary controls **837-A3** and **837-A4** is to be mounted vertically, the capillary end of the bulb should always be positioned higher than the termination end of the bulb.

When mounting the bulb horizontally, the word “**TOP**” stamped near the capillary of the bulb should be positioned upward toward the 12 o’ clock position. The capillary end of the bulb should never be higher than the termination end of the bulb. The direct vertical immersion devices in the catalog series **837-V** are conventionally mounted with the bulb downward, below the mechanism.

They must not be mounted with the bulb up. Since the horizontal immersion device is not available in a Type 4 & 13 enclosure, the corresponding vertical immersion device can be used. When the vertical immersion device is mounted horizontally, the word “**TOP**” stamped on the mounting thread “hex” should point upward toward the 12 o’ clock position.

The direct horizontal Immersion devices, in catalog series **837-H** should always be mounted with the mechanism above the bulb. The word “**TOP**” stamped on the mounting thread “hex” should point upward toward the 12 o’ clock position. Cat. No. **837-A2** is not cross-ambient and should not be used if the ambient temperature approaches or crosses over the set point as false temperature may occur.

Consult your local Rockwell Automation sales office or Allen-Bradley distributor for assistance on special applications.

* NEMA does not rate contacts to switch low-voltage and current. Bulletin 837 Styles A, H and V Temperature Controls are supplied with silver contacts. The devices are designed to deliver high force snap action to the contacts. This provides exceptional contact fidelity at 24V DC I/O card current level entry when the integrity of the enclosure is maintained.

Product Selection

Ordering Bulletin 837 Temperature Controls

When ordering Bulletin 837 Temperature Controls, consider the following:

- Device Style
- Adjustable Operating Range
- Adjustable Differential
- Maximum Temperature
- Mounting — Direct or Remote
- Enclosure Type

How to Order

- Step 1: Basic Device**
Select a catalog number for the basic device. See pages 13-56 and 13-57.
- Step 2: Modifications**
If required, add the appropriate modification suffix code(s) to the catalog number of the basic device. See pages 13-58 and 13-59.
- Step 3: Accessories**
If required, select appropriate accessories. See page 13-60.
- Step 4: Factory Options**
Factory set temperature controls. See page 13-61.

Catalog Number Explanation

Note: Catalog numbers must not include blank spaces.

837 – **A** **4** **A** **X** **5** **08** **X171**
a b c d e f

a

Style of Device	
Code	Description
A	Remote bulb and capillary
H	Direct horizontal immersion
V	Direct vertical immersion

b

Temperature Specifications	
See temperature specifications on page 13-56.	

c

Enclosure Type	
Code	Description
A	Type 1
E	Type 7 & 9 and 4 & 13
J	Type 4 & 13 metallic
S	Type 4X
None	Without enclosure

d

Type of Bulb and Capillary	
Code	Description
5	Copper bulb and capillary
6	Stainless steel bulb and capillary (required for Type 4X)
7	Copper capillary and bulb bronze armor
8	Stainless steel bulb and capillary bronze armor
9	Stainless steel bulb and capillary and armor (required for Type 4X)

e

Capillary Length	
Measured in feet, from end of bellows stem to end of bulb tip	

f

Modification to basic device selected from Modifications table. Add suffix codes in descending order whenever possible. (Optional. See pages 13-58...13-59.)
--



Style A — Type 1
with external manual reset option



Style A — Type 7 & 9 and 4 & 13 combined

Style A — Remote Bulb and Capillary**

Standard temperature controls shipped from the factory are set at the maximum operating range and minimum differential.

Temperature Specifications				Enclosure Type			
Adjustable Operating Range [°F]	Adjustable Differential [°F]**			Maximum Temperature [°F]	Bulb Length [in. (mm)]	Open Type (Without Enclosure)	Type 1
	Minimum Range	Mid Range	Maximum Range			Cat. No.	Cat. No.
-60...+50	6...46	2...38	2...16	250	3-3/4 (95)	837-A2	837-A2A
25...125	4...36	2...30	2...16	160	8-1/2 (216)	‡ 837-A3	‡ 837-A3A
80...190	14...54	7...45	3...20	240	8-1/2 (216)	‡ 837-A4	‡ 837-A4A
130...200	5...28	5...26	3...18	240	3-3/4 (95)	837-A5	837-A5A
140...290	13...63	7...52	3...24	340	3-3/4 (95)	837-A6	837-A6A
200...360	8...72	4...62	3...30	400	3-3/4 (95)	837-A7	837-A7A
260...430	9...72	5...62	3...28	470	3-3/4 (95)	§ 837-A60	§ 837-A60A
310...490	10...78	5...67	3...21	520	3-3/4 (95)	§ 837-A61	§ 837-A61A
380...570	12...87	5...78	4...35	600	3-3/4 (95)	§ 837-A62	§ 837-A62A

Style A — Remote Bulb and Capillary**

Standard temperature controls shipped from the factory are set at the maximum operating range and minimum differential.

Temperature Specifications				Enclosure Type			
Adjustable Operating Range [°F]	Adjustable Differential [°F]**			Maximum Temperature [°F]	Bulb Length [in. (mm)]	Type 4 & 13	Type 7 & 9 and 4 & 13*
	Minimum Range	Mid Range	Maximum Range			Cat. No.	Cat. No.
-60...+50	6...46	2...38	2...16	250	3-3/4 (95)	837-A2J	837-A2E
25...125	4...36	2...30	2...16	160	8-1/2 (216)	‡ 837-A3J	‡ 837-A3E
80...190	14...54	7...45	3...20	240	8-1/2 (216)	‡ 837-A4J	‡ 837-A4E
130...200	5...28	5...26	3...18	240	3-3/4 (95)	837-A5J	837-A5E
140...290	13...63	7...52	3...24	340	3-3/4 (95)	837-A6J	837-A6E
200...360	8...72	4...62	3...30	400	3-3/4 (95)	837-A7J	837-A7E
260...430	9...72	5...62	3...28	470	3-3/4 (95)	§ 837-A60J	§ 837-A60E
310...490	10...78	5...67	3...21	520	3-3/4 (95)	§ 837-A61J	§ 837-A61E
380...570	12...87	5...78	4...35	600	3-3/4 (95)	§ 837-A62J	§ 837-A62E

Note: Bulb and capillary controls have a 72 in. long capillary which includes the length of the bulb. Bulbs are 3/8 in. in diameter. Material is copper unless otherwise specified. See page 13-61. Special longer length capillaries, generally over 30 feet, will be equipped with longer bulbs depending upon temperature range and chemical fill. Capillary diameter (outside diameter) is 0.125 in.

- * Minimum differentials shown are approximate values. Deviations are negligible for most applications.
- ** The vapor pressure characteristics of the chemical fill in the bellows system do not respond linearly to temperature change from minimum to the maximum range setting of the control. The result is larger differential values at minimum temperature range setting and smaller values at the maximum temperature range setting. Differentials in the table are not constant over the adjustable range of the control. Therefore, the control should be selected on the basis of the adjustable operating range and the differential based upon the setting being at minimum, mid or maximum range. It may be necessary to move up or down in the table to select the most desirable control for the application.
- ‡ Cross-ambient controls are supplied with 8.5 in. long bulbs. Cross-ambient controls in the ranges of 25...190 °F require a larger volume of temperature-sensitive chemicals in the bulb than the additive volume contained in the capillary and bellows. For this reason, **bulb and capillary type cross-ambient controls cannot be supplied with bulbs shorter than 8.5 in.**
- § Supplied with stainless steel bulb and capillary to minimize oxides caused by elevated temperatures.
- * The combined Type 7 & 9 and 4 & 13 hazardous gas and dust service enclosure is supplied with special gasket and O-ring seal to diminish/exclude moisture, fluids, and dust from entering the enclosure. Enclosures rated 7 & 9 only are not designed to restrict moisture from entering the enclosure, which is common to outdoor service. Enclosure is rated for the following environments:
 CLASS I Groups C,D
 CLASS II Groups E,F,G
 CLASS III





Style V — Type 4 & 13
 Direct vertical immersion



Style H — Type 1
 Direct horizontal immersion shown with external manual reset

Style H — Direct Horizontal Immersion*

Standard temperature controls shipped from the factory are set at the maximum operating range and minimum differential.

Adjustable Operating Range [°F]	Temperature Specifications			Maximum Temperature [°F]	Enclosure Type	
	Adjustable Differential [°F]*				Open Type (Without Enclosure) Cat. No.	Type 1 Cat. No.
	Minimum Range	Mid Range	Maximum Range			
25...125	4...36	2...30	2...16	160	837-H1	837-H1A
110...200	8...41	6...34	3...18	240	837-H2	837-H2A
140...290	13...63	7...52	3...24	340	837-H3	837-H3A

Style V — Direct Vertical Immersion*

Standard temperature controls shipped from the factory are set at the maximum operating range and minimum differential.

Adjustable Operating Range [°F]	Temperature Specifications			Maximum Temperature [°F]	Enclosure Type		
	Adjustable Differential [°F]*				Open Type (Without Enclosure) Cat. No.	Type 1 Cat. No.	Type 4 & 13 Cat. No.
	Minimum Range	Mid Range	Maximum Range				
25...125	4...36	2...30	2...16	160	837-V1	837-V1A	837-V1J
110...200	8...41	6...34	3...18	240	837-V2	837-V2A	837-V2J
140...290	13...63	7...52	3...24	340	837-V3	837-V3A	837-V3J

Note: Direct immersion controls are not available in combined Type 7 & 9 and 4 & 13 Hazardous Duty enclosures.

- * Minimum differentials shown are approximate values. Deviations are negligible for most applications.
- * The vapor pressure characteristics of the chemical fill in the bellows system do not respond linearly to temperature change from minimum to the maximum range setting of the control. The result is larger differential values at minimum temperature range setting and smaller values at the maximum temperature range setting. Differentials in the table are not constant over the adjustable range of the control. Therefore, the control should be selected on the basis of the adjustable operating range and the differential based upon the setting being at minimum, mid or maximum range. It may be necessary to move up or down in the table to select the most desirable control for the application.

Temperature Controls

Modifications

Ordering Modifications

Modifications are ordered by adding the appropriate modification suffix code to the catalog number of the basic device. Add suffix codes to the catalog number in descending order whenever possible (highest number first).

Modifications

Contact Blocks — Trip temperature-indicating scales are supplied on controls with standard contact block.

Description	Rating	Symbol	Suffix Code	
Automatic Operation				
Standard contact block — Single-pole, double-throw, snap-action. Supplied when a contact block suffix is not added to the catalog number.	Control circuit rating: See Specifications on page 13-54		—	
Single-pole double-throw — slow acting contact with no snap action. Contacts close on rise and close on fall with an open circuit between contact closures.	Control circuit rating: AC-125VA, 24...250V		*⊛	X171
Single-pole single-throw, normally open — closes on rise.	0.5 Hp, 115V AC 1 Hp, 230V AC Control circuit rating: AC-125VA, 24...110V		*⊛	X221
Single-pole single-throw, normally closed — opens on rise.	AC-345VA, 110...600V DC-57.5VA, 110...250V		*⊛	X231
Single-pole single-throw, normally open — closes on rise.	1 Hp, 115V AC 1.5 Hp, 230V AC Control circuit rating: AC-600VA, 110...600V		*⊛	X321
Single-pole single-throw, normally closed — opens on rise.	DC-57.5VA, 110...250V		*⊛	X331
External Manual Reset†				
Single-pole single-throw, normally open — contacts open at a predetermined setting on fall and remain open until system is restored to normal run conditions, at which time contacts can be manually reset.	Non-inductive: 5 A, 240V 3 A, 600V Control circuit rating: AC-125VA, 24...600V DC-57.5VA, 115...230V		*‡§♣	X140
Single-pole single-throw, normally closed — contacts open on rise and remain open until system is restored to normal run conditions, at which time contacts can be manually reset.			*‡§♣	X150
Single-pole double-throw, one contact normally closed — contact opens on rise and remains open until system is restored to normal run conditions, at which time contact can be manually reset. A second contact closes when the first contact opens.			*‡§♣	X15A

* Contact blocks not available for field conversion or replacement.

⊛ Minimum specified differential value approximately doubles.

‡ **Manual reset devices cannot be supplied with an adjustable differential. Differential is approximately three times the minimum published differential of the corresponding adjustable differential control. Not available on Type 4X enclosed devices.**

§ Available only for replacement of complete open type control in an existing Type 1 or 4 & 13 enclosure. Replacement in a Type 7 & 9 enclosure is not available because it would void UL and CSA.

♣ Type 7 & 9 enclosures for manual reset devices are not also rated Type 4 & 13.

Note: NEMA does not rate contacts to switch low voltage and current. Bulletin 837 Styles A, H, and V temperature controls are supplied with silver contacts. The devices are designed to deliver high force snap action to the contacts. This provides exceptional contact fidelity at 24V DC I/O card current level entry when the integrity of the enclosure is maintained.



Modifications are ordered by adding the appropriate modification suffix code to the catalog number of the basic device. Add suffix codes to the catalog number in descending order whenever possible (highest number first).

Modifications

Tamper-Resistant Adjustment

Modification	Description	Suffix Code
Tamper-resistant adjustment	Range and differential adjustment screws are designed so that after a setting has been applied to the control, the adjustment screws can be broken off with a pliers. Modification does not include factory setting charge. Note: The "break-off" adjustment screw(s) will not be broken off unless a factory setting is given and the order specifies "Break off Adjustment Screw(s)". See paragraph entitled "Factory-Set Temperature Controls" on page 13-55.	X4
Neon pilot light 120V AC	A high-intensity neon pilot light is available for 120V AC, 60 Hz applications and can be wired for ON or OFF operation. The current rating is 1.0 mA.*	X9
Red LED pilot light 24V DC	A high-intensity LED 24V DC pilot light is available to meet the requirements of the automotive, machine tool builders, and other industries. The current rating is 22 mA and can be wired for ON or OFF operation.*	X15
Green LED pilot light 24V DC		X18
Armored capillary	Added capillary protection for copper alloy bulb and capillary type temperature controls. Supplied with bronze armor. For use on Cat. Nos. 837-A2...837-A7 only.	X706
	Added capillary protection for stainless steel bulb and capillary type temperature controls. Supplied with stainless steel armor. For use on Cat. Nos. 837-A60...837-A62 only.	X906
Manual test button	Allows electrical testing of circuit. See photo on page 13-57. Not available for all contact blocks.	X47
5-Pin mini-type receptacle no pilot light	Supplied with receptacle ready for field wiring.*	X42
5-Pin mini-type receptacle with pilot light	Supplied with receptacle and pilot light ready for field wiring. Pilot light suffix code X9 (120V AC Neon), suffix code X15 or X18 (24V DC LED) must also be specified. See suffix code X9 , X15 or X18 description above.*	X43
5-Pin micro-type receptacle no pilot light	Supplied with receptacle ready for field wiring.*	X142
5-Pin micro-type receptacle with pilot light	Supplied with receptacle and pilot light ready for field wiring. Pilot light suffix code X9 (120V AC Neon) or suffix code X15 or X18 (24V DC LED) must also be specified. See suffix code X9 , X15 or X18 description above.*	X143

* Not available on combined Type 7 & 9 and 4 & 13, Type 4X, and manual reset devices.

* Not available for combined Type 7 & 9 and 4 & 13 or Type 4X enclosures.

Ordering Accessories

Accessories are ordered as separate catalog numbers. Select the required accessories from the accessories table below.

Angle Mounting Brackets

Description	Bracket Type	Cat. No.
For mounting one or two open type Bulletin 836 Style A Pressure Controls or Bulletin 837 Temperature Controls on an enclosure mounting plate.	Single bracket	836-N11
	Dual mounting bracket	836-N12

Hardware Kits for Mounting Open Type Controls in Special Enclosures

Description	Kit Contents	Material	Cat. No.
	Style A Controls		
For mounting open type controls in special enclosures by user. Allows ease of running a capillary external to the enclosure. For use with Type 1 and 4 & 13 enclosures with wall thickness up to 0.25 in. (6.35 mm).	Bulb and capillary with armored capillary	Brass	837-N17

Thermostat Wells*

Description	Material	Type of Control	Control Bulb Size [in. (mm)]	Cat. No.
Thermostat wells are used when inserting the sensing bulb into a pressurized system. This allows removal of the sensing bulb for recalibration or inspection without having to discharge the system	Brass	Remote standard capillary	3-3/4 (95)	837-N1
			8-1/2 (216)	837-N6
		Remote armored capillary	3-3/4 (95)	837-N3
			8-1/2 (216)	837-N7
	Type 316 Stainless steel	Remote standard capillary	3-3/4 (95)	837-N12
			8-1/2 (216)	837-N13
		Remote armored capillary	3-3/4 (95)	837-N14
			8-1/2 (216)	837-N15
Direct immersion	3-1/2 (89)	837-N16		

Packing Glands*

Description	Material	Type of Control	Cat. No.
Packing glands form a seal around any desired position of the capillary, allowing any length of capillary to be inserted into the vessel where temperature is to be sensed.	Brass	Remote standard capillary	837-N5
		Remote armored capillary	837-N4

Figure 6
Thermostat Wells

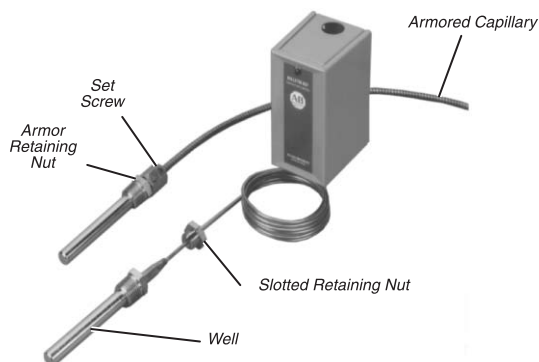

Packing Glands

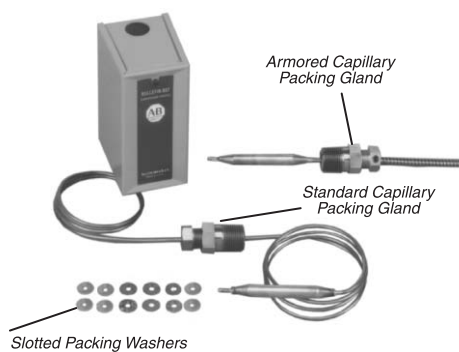

* External pressure rating — 1000 psi at 600°F maximum.
 * Maximum sealing pressure — 50 psi.

Renewal parts are ordered as separate catalog numbers. See the table below.

Contact Block Replacement Kit

Description	Cat. No.
Kit consists of a standard contact block and instructions.	836-N2

Replacement Finger-Safe Contact Block Cover Kit

Description	Cat. No.
Clear contact block cover provides IP2X Finger-Safe protection.	41162-908-01

Factory Options

Factory-Set Temperature Controls

Ordering factory-set temperature controls

- When a specific factory setting is requested, the specific terminal connections must be specified — e.g., N.O. or N.C. It must also be specified whether the contact operation is occurring on either increasing or decreasing pressure. For example:

Normally Closed (N.C.) contacts to open at* °F increasing temperature and close at* °F decreasing temperature.

—OR—

Normally Open (N.O.) contacts to close at* °F increasing temperature and open at* °F decreasing temperature.

- If minimum differential is not critical and the inherent minimum differential satisfies the application, specify the factory setting as follows:

Normally Closed (N.C.) contacts to open at* °F increasing temperature. Minimum differential.

—OR—

Normally Open (N.O.) contacts to close at* °F increasing temperature. Minimum differential.

Note: Typical setting tolerance is ± 1 °F.

Two Controls in One Enclosure

Bulletin 837 Style A Bulb and Capillary Type temperature controls that function independently may be mounted side by side in a single Type 1 enclosure. This design is ideal for installations where two controls would ordinarily be mounted. Each dual unit can be a combination of a bulb and capillary type temperature control and a Bulletin 836 Style A pressure control. See respective product tables. To order this arrangement, specify the two desired catalog numbers in their mounted position within the dual enclosure to form a single catalog number.

Type 4X Enclosures

Bulb and capillary controls can be furnished in Type 4X ROSITE polyester enclosures. Because of the intended protection by specifying Rosite, temperature controls will be supplied only with stainless steel bulb and capillaries or stainless steel bulb, capillary, and armor.

Special Length Capillary and Material

A price addition, varying with the specific requirements, will be added to each control when requesting non-standard length or material for capillary, bulb, or armor. The non-standard devices are those that are not listed in the tables on pages 13-56 and 13-57. Consult your local Rockwell Automation sales office or Allen-Bradley distributor for pricing.

During the manufacturing process, the bellows assembly is cured in an oven at the maximum range temperature of the control to ensure long control life.

* Specify °F (Fahrenheit) unless otherwise noted.

Standards Compliance

- UL 873
- NEMA ICS-2
- UL 1203 (Haz. Loc.)
- IEC 529/IP2X
- CSA 22.2 No. 14

Certifications



File and Guide Numbers

	UL		CSA	
	File Number	Guide Number	File Number	Class
	E65556	XAPX	LR1234	1222-01
	E64971 (Haz.Loc.)	XBDV	LR11924 (Haz. Loc.)	3218-02
Bulletin 837	Hazardous Location enclosed devices are not CE compliant.			

Temperature Controls

Approximate Dimensions

Dimensions in inches (millimeters). Dimensions are not intended to be used for manufacturing purposes.

Remote Bulb and Capillary Type

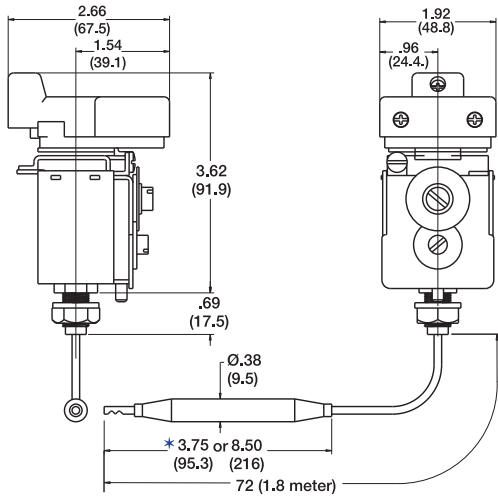

Open Type
Approximate shipping weight 2-1/2 lb (1.1 kg)

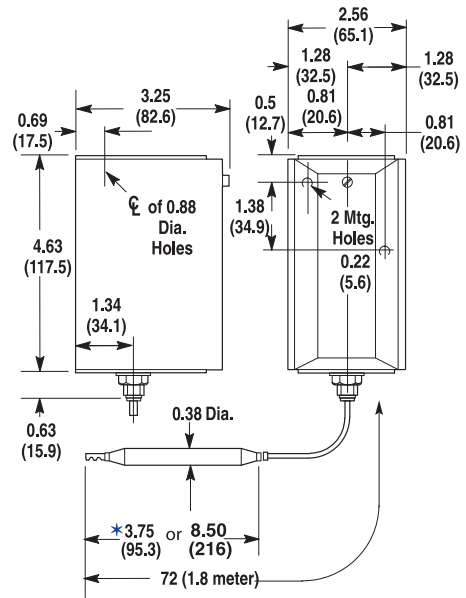

Type 1
Approximate shipping weight 3 lb (1.4 kg)

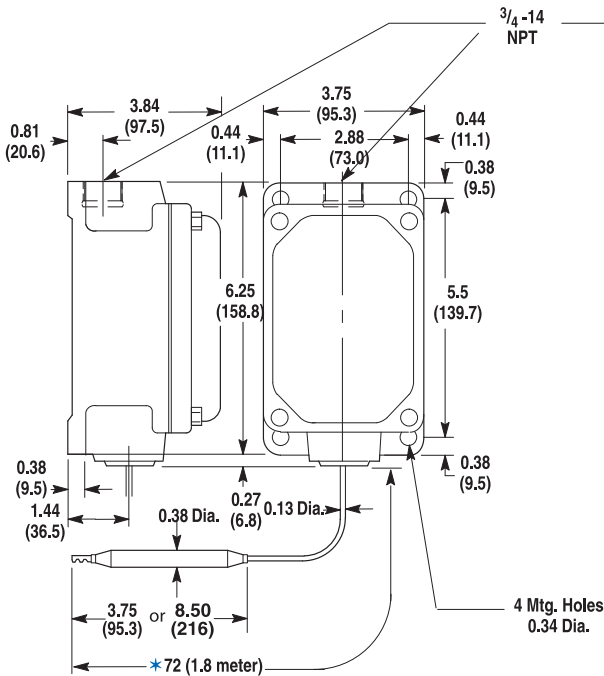

Types 7 & 9 and 4 & 13 combined
Approximate shipping weight 9 lb (4.1 kg)

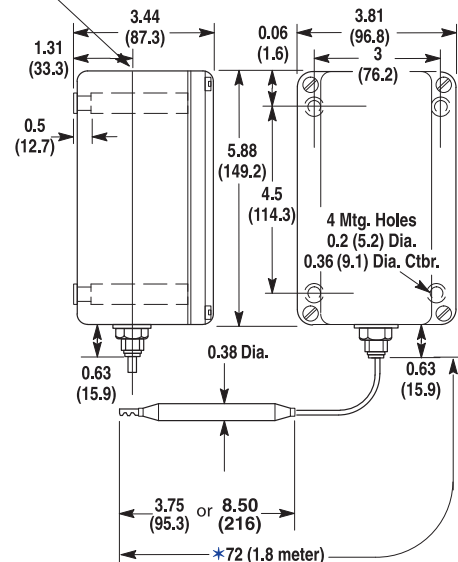

Type 4 & 13
Approximate shipping weight 3 lb (1.4 kg)

* Dimension is 8.5 in. for Cat. Nos. 837-A3 and 837-A4 controls.

Dimensions in inches (millimeters). Dimensions are not intended to be used for manufacturing purposes.

Direct Vertical Immersion Type

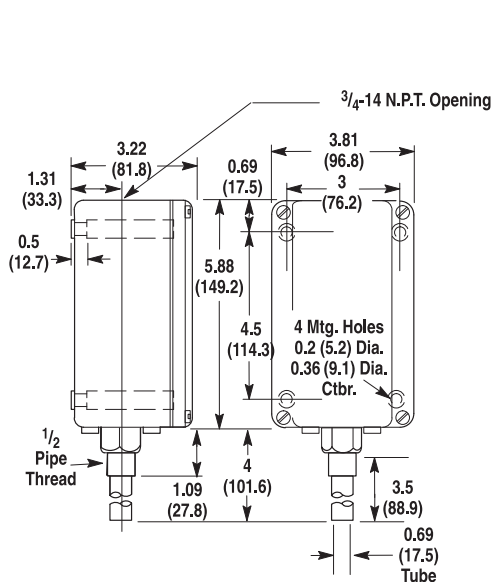

Type 4 & 13
 Approximate shipping weight 3 lb (1.4 kg)

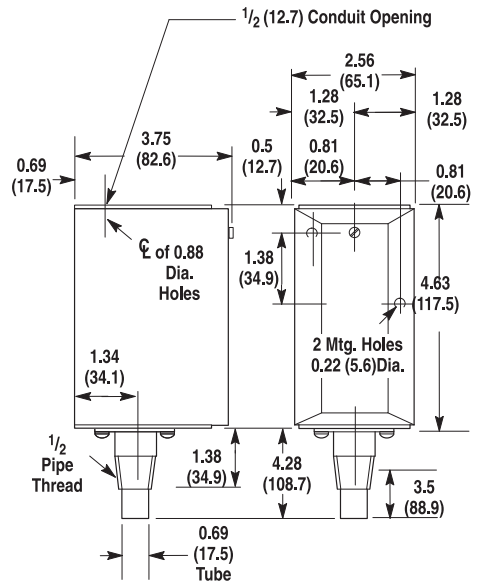

Type 1
 Approximate shipping weight 3 lb (1.4 kg)

Direct Horizontal Immersion Type

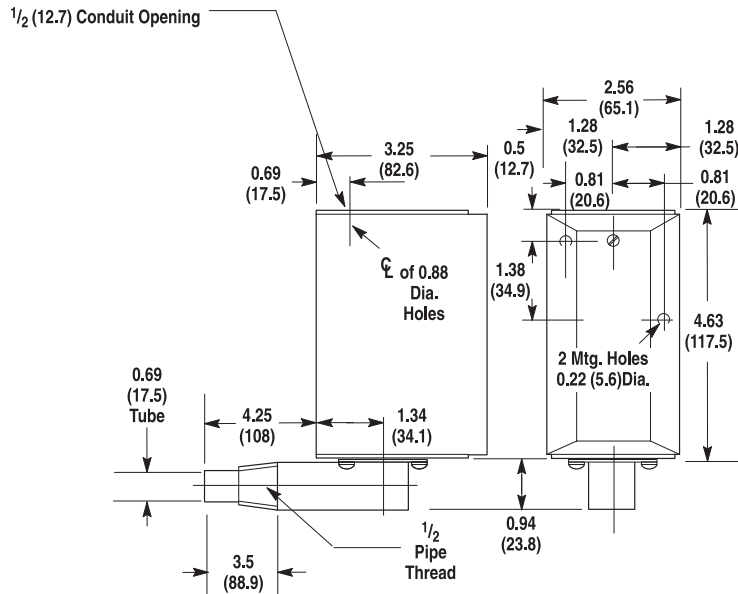

Type 1
 Approximate shipping weight 4 lb (1.8 kg)

Temperature Controls

Approximate Dimensions, Continued

Dimensions in inches (millimeters). Dimensions are not intended to be used for manufacturing purposes.

Thermostat Wells and Packing Glands

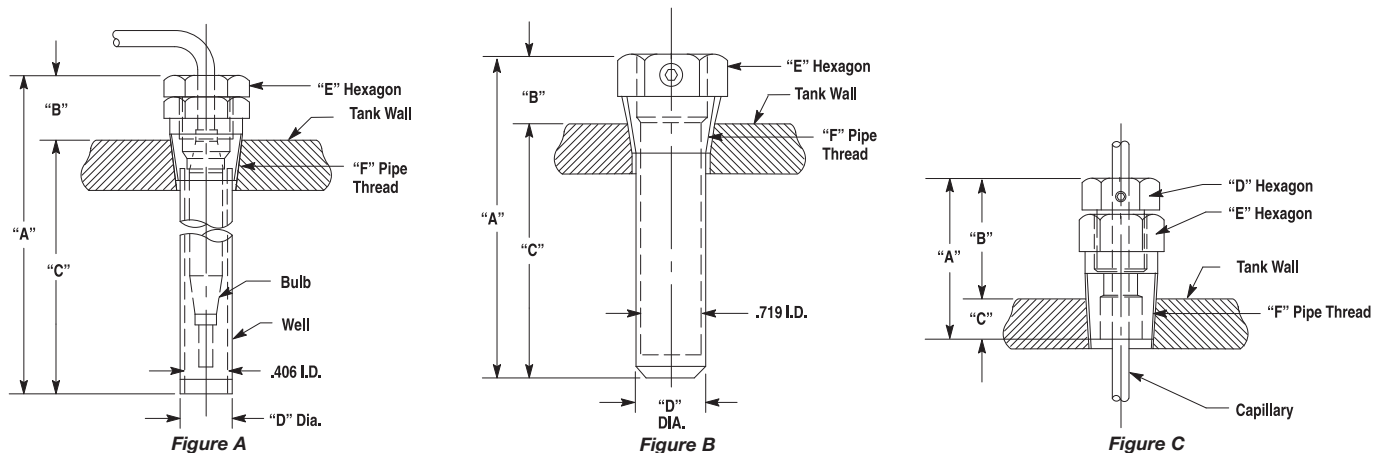

Note: Packing gland can be used to form a seal anywhere along length of capillary.

Cat. No.	Figure	A	B	C	D	E	F
837-N1	A	4-5/8 (117.6)	23/32 (18.3)	3-29/32 (99.2)	17/32 (13.5)	7/8 (22.2)	1/2 NPT
837-N2	B	3-27/32 (97.6)	27/32 (21.4)	3 (76.2)	27/32 (21.4)	1-1/8 (28.6)	3/4 NPT
837-N3	A	5-13/32 (137.3)	1-1/2 (38.1)	3-29/32 (99.2)	17/32 (13.5)	7/8 (22.2)	1/2 NPT
837-N4	C	2-5/32 (54.8)	1-21/32 (42.1)	7/16 (11.1)	3/4 (19.1)	7/8 (22.2)	1/2 NPT
837-N5	C	2-5/32 (54.8)	1-21/32 (42.1)	7/16 (11.1)	3/4 (19.1)	7/8 (22.2)	1/2 NPT
837-N6	A	9-5/8 (244.5)	13/16 (20.6)	8-13/16 (223.8)	5/8 (15.9)	7/8 (22.2)	1/2 NPT
837-N7	A	10-5/32 (258)	1-1/2 (38.1)	8-13/16 (223.8)	5/8 (15.9)	7/8 (22.2)	1/2 NPT
837-N12	A	4-5/8 (117.6)	23/32 (18.3)	3-29/32 (99.2)	17/32 (13.5)	7/8 (22.2)	1/2 NPT
837-N13	A	9-5/8 (244.6)	13/16 (20.6)	8-13/16 (223.8)	5/8 (15.9)	7/8 (22.2)	1/2 NPT
837-N14	A	5-13/32 (137.3)	1-1/2 (38.1)	3-29/32 (99.2)	17/32 (13.5)	7/8 (22.2)	1/2 NPT
837-N15	A	10-5/16 (262)	1-1/2 (38.1)	8-13/16 (223.8)	5/8 (15.9)	7/8 (22.2)	1/2 NPT
837-N16	B	3-27/32 (97.6)	3 (76.2)	27/32 (21.4)	27/32 (21.4)	1-1/8 (28.6)	3/4 NPT